

**ALLIED
ORDNANCE
PUBLICATION**

**AOP-39
(Edition 3)**

NATO INTERNATIONAL STAFF - DEFENCE INVESTMENT DIVISION

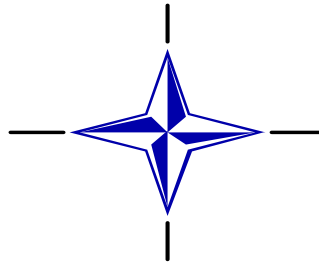

**GUIDANCE ON THE ASSESSMENT AND DEVELOPMENT
OF INSENSITIVE MUNITIONS (IM)**

March 2010

**NORTH ATLANTIC TREATY ORGANIZATION
NATO STANDARDIZATION AGENCY (NSA)**

NATO LETTER OF PROMULGATION

17 March 2010

1. AOP-39 (Edition 3) - GUIDANCE ON THE ASSESSMENT AND DEVELOPMENT OF INSENSITIVE MUNITIONS (IM) is a NATO/PFP UNCLASSIFIED publication. The agreement of NATO nations to use this publication is recorded in STANAG 4439.
2. AOP-39 (Edition 3) is effective upon receipt and replaces AOP-39 (Edition 2) which should be destroyed in accordance with local document destruction procedures.
3. AOP-39 (Edition 3) contains only guidance information and is not subject to the ratification procedures.



Juan A. MORENO
Vice Admiral, ESP(N)
Director, NATO Standardization Agency



NATION	RESERVATIONS

RECORD OF AMENDMENTS

Change Date	Date entered	Effective Date	By Whom Entered

TABLE OF CONTENTS

	<u>Page</u>
NATO LETTER OF PROMULGATION	II
RECORD OF AMENDMENTS	IV
TABLE OF CONTENTS	V
1. INTRODUCTION.....	1
2. AIM	1
3. SCOPE.....	1
4. DEFINITIONS.....	1
5. METHODOLOGY OF IM ASSESSMENT	1
5.1 General	1
5.2 Identifying the Threats	2
5.3 Identifying the Munition Configurations.....	2
5.4 Assessing the Response of the Munition to the Threats	3
5.5 Generating the IM Signature for Any Particular Configuration	4
6. IM ASSESSMENT INFORMATION AND REPORT.....	4
7. IM DESIGN AND DEVELOPMENT.....	4

ANNEXES

A. DEFINITIONS	A-1
B. APPLICATION OF THE HAZARD PROTOCOLS.....	B-1
C. ASSESSMENT OF FAST/SLOW HEATING	C-1
D. ASSESSMENT OF BULLET/FRAGMENT IMPACT	D-1
E. ASSESSMENT OF SYMPATHETIC REACTION	E-1
F. ASSESSMENT OF SHAPED CHARGE JET IMPACT	F-1
G. FULL SCALE TEST PROCEDURES	G-1
H. CONDUCT AND REPORTING OF FULL SCALE TESTS	H-1
I. INTERPRETATION OF MUNITION RESPONSES	I-1
J. PRESENTING THE IM SIGNATURE.....	J-1
K. IM ASSESSMENT REPORT	K-1
L. IM DESIGN TECHNIQUES	L-1

1. INTRODUCTION

- 1.1 Technological advances in the design of explosive ordnance are making possible the development of a range of munitions termed Insensitive Munitions (IM) or Munitions à Risques Atténués (MURAT) which are less dangerous than previous weapons when subjected to accidental and combat stimuli. Such munitions remain effective in their intended application, and are less sensitive than their predecessors to extreme but credible environments such as heat, shock or impact.
- 1.2 Introduction of IM into service is intended to enhance the survivability of logistic and tactical combat systems, minimise the risk of injury to personnel, and provide more cost effective and efficient transport, storage, and handling of munitions.

2. AIM

- 2.1 The aim of this AOP is to provide guidance on implementing the policy and requirements specified in STANAG 4439.

3. SCOPE

- 3.1 This AOP gives guidance on:
 - The methodology for carrying out an IM assessment.
 - The design techniques for developing an IM.
 - The reporting of the IM assessment.
- 3.2 The guidance contained in this document can be applied to all non-nuclear munitions, either at the earliest stage of design, newly developed, product improved, replenishment purchased, or older designs still in service, during all phases of life, from manufacture to target or disposal.
- 3.3 The IM assessment is complimentary to a comprehensive assessment of safety and suitability for service in accordance with STANAG 4297 and AOP-15, and Hazard Classifications in accordance with the STANAG 4123.

4. DEFINITIONS

- 4.1 Annex A provides a list of definitions specific to this AOP.

5. METHODOLOGY OF IM ASSESSMENT

5.1 General

5.1.1 The IM assessment is a process that evaluates how a munition will likely respond to the IM threats specified in STANAG 4439 and whether it complies with the IM requirements.

5.1.2 The IM assessment consists of:

- Identifying the threats
- Identifying the munition configurations
- Assessing the response of the munition to the threats
- Generating the IM signature for any particular configuration

5.1.3 There are benefits when preparing IM assessment plans in coordinating the testing requirements with those for other assessments including those conducted for hazard classification in accordance with STANAG 4123, system vulnerability, and those identified as a result of applying the safety assessment process described in AOP-

15. When testing is intended to serve multiple purposes and satisfy multiple requirements, the test plans should be coordinated with all appropriate authorities.

5.2 Identifying the Threats

5.2.1 STANAG 4439 defines a number of threats to which a munition is likely to be exposed during its life cycle. Some of these threats are common to all munitions; others arise because of exposure of the munition to a specific operational or logistic environment.

5.2.2 In order to help interoperability and facilitate modification of life cycle, it is recommended that the IM assessment covers an internationally agreed baseline range for each threat as defined in Table 1 below.

Table 1: Threat and Baseline Threat Range

THREAT	REQUIREMENT	BASELINE THREAT RANGE
Magazine/store fire or aircraft/vehicle fuel fire (Fast Heating)	No response more severe than Type V (Burning)	Average temperature between 550°C and 850°C until all munitions reactions completed. 550°C reached within 30s from ignition.
Fire in an adjacent magazine, store or vehicle (Slow Heating)	No response more severe than Type V (Burning)	Between 1°C and 30°C per hour heating rate from ambient temperature.
Small arms attack (Bullet Impact)	No response more severe than Type V (Burning)	From one to three 12,7mm AP round, velocity from 400 m/s to 850m/s.
Fragmenting munitions attack (Fragment Impact)	No response more severe than Type V (Burning)	Steel fragment from 15 g with velocity up to 2600m/s and 65 g with velocity up to 2200m/s.
Shaped charge weapon attack (Shaped Charge Jet Impact)	No response more severe than Type III (Explosion)	Shaped charge caliber up to 85 mm.
Most severe reaction of same munition in magazine, store, aircraft or vehicle (Sympathetic Reaction)	No propagation of reaction more severe than Type III (Explosion)	Detonation of donor in appropriate configuration.

Note: The threats recommended for Hazard Classification purpose are in the ranges defined in Table 1.

5.2.3 Analysis of the life cycle may identify credible threats that are either additional to those selected in STANAG 4439 or which are outside the range specified in Table 1.

5.2.4 Conversely, analysis of the life cycle may identify situations where the threat ranges in Table 1 are not credible, and could be reduced or discounted.

5.2.5 In both cases the rationale behind any variation must be justified.

5.3 Identifying the Munition Configurations

5.3.1 A munition can be found in many different configurations (transport, tactical, operational, fuzed, unfuzed...) throughout its life cycle. Persons directly involved with the munition should be consulted so that information on how the munition will be used, handled and operated throughout its service life and what will be its duration in that situation can be incorporated into each of the munition situations that have been previously defined.

5.3.2 The nature of information that is needed and the appropriate stakeholders who should be consulted for establishing the life cycle profile and determining the associated configurations is shown in Table 2.

Table 2: Stakeholder and situation information

STAKEHOLDER	INFORMATION
Operational User	Details on the munition's role, tactical use and deployment
Logistician	Details on re-supply, manner of storage and transportation of the munition
Safety Authority	Details of safety regulations that could affect, handling, storage, transportation and deployment of the munition
In Service Manager	Details on munition inspection, maintenance cycle, disposal and carriage on weapon platforms
Design Authority	Details on the munition configuration, dimensions, packaging and explosive components.

5.3.3 If it is not feasible to assess all configurations in detail, the most pertinent configurations should be identified based on:

- The amount of its life spent in those configurations.
- The probability of being exposed to a specific threat in those configurations.
- The consequences to the surroundings of any reaction in those configurations.
- The configuration guidance provided in the test STANAGs.

5.4 Assessing the Response of the Munition to the Threats

5.4.1 To assess the response/reaction level for each configuration of interest, the following factors should be considered:

- a. Type and magnitude of the stimulus associated with the threat range.
- b. Explosiveness and sensitiveness of the energetic materials (EMs) used in the munition.
- c. Design of the munition.
- d. Component interactions.
- e. Selected Configuration.

5.4.2 Information that can be used to perform this assessment includes but may not be limited to:

- a. Read across from similar designs.
- b. Modelling and analysis.
- c. Energetic materials characterisation.
- d. Laboratory scale test results.
- e. Small scale and component level test results.
- f. Full scale test results.

5.4.3 The process for determining the response level to each of the IM threats may be based on the hazard assessment protocols. Compared to AUR testing in isolation, use of the protocols can increase the level of confidence and range of validity of the IM assessment.

5.4.4 Protocols are ordered procedures described by a flow chart, through which modelling, small scale testing, generic testing, data on similar munitions or munitions using the same or similar EM and expert analysis can be used. Confidence in the validity of the result is directly linked to the level of detail provided. The protocols may be used in an iterative manner to establish the sensitivity of the assessment to variations in threat stimulus level, EM formulation, munition design, packaging and storage /transport configuration. Guidance on the application of protocols is given at Annex B. Protocols developed by The Technical Cooperation Program (TTCP) nations during the early 90's and NIMIC nations during the mid 90's for each of the IM threats are at Annexes C-F. These protocols are neither exhaustive nor exclusive, and users of the protocols should seek to use the most up to date and well validated tools available to them.

5.4.5 If it is not possible to use the protocols or other methodologies such as a risk-based methodology, the minimum requirement for assessing the response of a munition to a hazard stimulus is full-scale testing in accordance with the appropriate STANAGs (Annex G). Guidance on the conduct and reporting of full scale tests is provided in Annex H. Guidance on the interpretation of results is provided in Annex I.

5.5 Generating the IM Signature for Any Particular Configuration

5.5.1 The IM signature is a summary of the responses of a specific configuration of a munition to all of the IM threats. A munition may have several IM signatures representing various configurations within multiple life cycles. Each signature is a snapshot of the results of the IM assessment.

5.5.2 From the different IM signatures corresponding to the worst credible life cycle configuration identified for each considered threat, it is possible to define the IM compliance signature. For this particular signature, the relevant configurations and threats have to be clearly reported.

5.5.3 Methods of presenting IM signatures are provided in Annex J

6. IM ASSESSMENT INFORMATION AND REPORT

6.1 The result of the IM assessment, including supporting information such as explosive characterisation testing, sub-scale generic testing, modelling, read across from other weapons, threat assessment, expert analysis and full scale testing, needs to be collated and provided by the Nation developing the munition in accordance with the statement of agreement in STANAG 4439.

6.2 Together with justification where appropriate, the IM Assessment report shall include:

- a. An executive summary
- b. Munition system information.
- c. The assessed configuration(s) and the threat ranges
- d. The supporting information.
- e. The IM signature (s)

6.3 It is recommended that at least the executive summary includes as much detail as possible to be releasable to a requesting nation upon receipt of a request through appropriate national channels.

6.4 Guidance on the structure and content of the IM assessment report is given in Annex K.

7. IM DESIGN AND DEVELOPMENT

7.1 IM should be considered at the earliest stages of system design and development. In order to reduce the risk that the IM requirements will not be met, the design of the munition needs to include appropriate EMs and/or to make use of applicable IM design techniques. The hazard assessment protocols can be used during the development of a munition to anticipate potential hazards, identify design solutions and help mitigate hazards of existing munitions

7.2 Application of IM design techniques is needed whether the munition is a new development, a product improvement, or a replenishment item. It is important that such techniques are addressed collectively through a systems design approach, rather than being applied in isolation.

7.3 There are a number of possible techniques which might be used. Further guidance on IM design is given in Annex L.

DEFINITIONS

1. **Explosiveness**
A measure of the explosive response to a given stimulus in a defined system. It is dependent not only on the explosive, but also on the mass, physical state, configuration and confinement (NATO AC/326 AOP-38 edition 3).
2. **IM Assessment**
A process to determine the compliance of a munition with the IM requirements (STANAG 4439 edition 3).
3. **IM Signature**
A representation of the IM level of the munition, i.e. the response level of the munition to the IM threats (STANAG 4439 edition 3)
4. **Insensitive Munitions (IM) or Munitions à Risques Attenués (MURAT)**
Munitions which reliably fulfill their performance, readiness and operational requirements on demand and which minimize the probability of inadvertent initiation and severity of subsequent collateral damage to weapon platforms, logistic systems and personnel when subjected to selected accidental and combat threats (STANAG 4439 edition 3).
5. **Munition Response**
The result (such as blast, overpressure, fragment spray and heat) produced by a munition as a consequence of stimuli generated by a threat or combination of threats.
6. **Munitions Threat Analysis (MTA)**
The identification and analysis of the specific threats that a munition may face during its life cycle.
7. **Protocol**
An ordered procedure in the form of a flow chart directing the user through the evaluation of a hazard area.
8. **Sensitiveness**
The probability or a measure of the ease of being initiated by a specified stimulus (NATO AC/326 AOP-38 edition 3).
9. **Stimulus**
The applied energy or power such as current, voltage, mechanical impact, friction, or any other physical phenomenon such as (rate of) change of current, or pressure, which is capable of initiating directly or indirectly an explosive event. (NATO AC/326 AOP-38 edition 3).
10. **Threat**
A condition that is a prerequisite to a mishap. Any phenomenon –environmental force or intrinsic effect– having the potential to induce an adverse effect in the munition compromising its safety or its suitability for service. It is characterized by its nature, severity or probability of occurrence (NATO AC/326 AOP-38 edition 3).

APPLICATION OF HAZARD PROTOCOLS

Overview

1. Full scale testing involves small statistical samples that may not provide adequate confidence in the likely response of a munition. To address the problems of full scale testing, and to increase confidence in IM assessments, a detailed understanding of the reactive behaviour of energetic materials is required along with an understanding of their interaction with hazard stimuli in conjunction with hardware characteristics and full-scale configurations is needed. The evidence required to support response predictions can be determined by analyzing the initiation and reaction mechanisms that the various stimuli are known to induce in the energetic materials.

2. A hazard assessment protocol is an ordered procedure that results in a flow chart directing the user through the evaluation of a hazard area. Once a threat stimulus has been identified and quantified, hazard protocols identify the response "paths" that this stimulus is likely to instigate and must, therefore be considered, and also the information required in order to perform an assessment of the hazard. Since such an assessment is based on a logical process and is conducted for a munition in a real environment, subject to real threats, it will have more value than the results of a small number of go/no-go full-scale hazard tests.

3. Each protocol consists of a decision tree flow chart that examines the science of successive events in the hazard/munition interaction. In this way, it characterises the stimulus, then its interaction with the munition, and finally the response of the munition. Each box (decision point) in the flow chart identifies the information required, and in what order, to make a decision and follow the process to the next box. In the simplest terms, then, a hazard assessment protocol is nothing more than an orderly process for viewing the hazard areas, and defining what information is needed to assess the response of munitions to those hazards.

Context

4. Traditional methods of hazard analysis depend on standard go/no-go or pass/fail tests, and the experience and judgment of cognisant individuals. Inevitably, this approach places emphasis on large scale tests of major components or the full-scale munition. Such large scale tests have several disadvantages. They contribute very little to the understanding of the fundamental mechanisms occurring in each hazardous situation. They are extremely costly and hence only a few are undertaken. Interpretation of their results is complicated by the problems associated with the statistical probability of an inadvertent reaction with the small number of tests which are conducted. The test design is for a "pass", with the response giving no indication of how far the stimulus is from conditions that could induce a very different response. There is no guarantee that you will see all the possible response mechanisms.

5. Limiting the assessment process to some standard pass/fail test may reduce time and costs, but there is no guarantee that the test represents the range of munition + environment + stimuli that the munition is likely to see. There is little mechanistic understanding involved that would allow the response of the munition to some other combination of environment and stimuli to be predicted (in terms of both initiation and output). The probabilistic nature of hazard occurrence is an issue. For example, if the probability of seeing an explosion is one in a thousand, the probability of seeing an explosion in two tests is 0.02%. In fact it would take 2,944 tests to be 95% certain of seeing one explosion. So while pass/fail tests are appealing in a simplistic sense – it either passed or failed – they do not provide a useful predictive capability, or a worthwhile degree of assurance to National Authorities that their results represent the true IM level of a munition. Confidence can be increased by using other methods.

6. A need for some large scale tests will probably always exist; to confirm the reaction level prediction or where no better techniques exist. However, in developing this methodology it is anticipated that substantial munition design and development and assessment can occur based on the results of laboratory and small scale tests, theoretical analyses and numerical modeling. Significantly fewer full-scale tests will be required for confirmation of the methodology's predictions.

Background

7. The Technical Cooperation Program (TTCP) Conventional Weapons Action Group 11 (WAG-11) was formed in a climate where it was felt by the international community of technical experts that the mechanistic understanding of the phenomena involved in energetic materials hazard assessment had advanced to the point where a science based methodology was possible. The detailed protocols presented here are primarily the output of the WAG-11 programme that ran from 1987 to 1994.

8. From the beginning, it was recognized that in outlining such a methodology, in addition to the benefits described above, areas of technical deficiency would be clearly identified for future research, and that the protocols would need to be continually updated as new knowledge emerged. They were passed to the NATO Munitions Safety Information and Analysis Center (MSIAC, formerly NIMIC) in 1995, and this organization has continued to update and extend their scope and relevance, holding a series of workshops to tap the collective expertise of the international technical community. The simplified protocols and lists of relevant tests and techniques are largely the product of these workshops.

Using Hazard Protocols

9. The protocol process is a decision logic flow which allows for the assessment of a hazard scenario. It is determined and expressed in a decision tree format. The process asks questions and directs certain actions be undertaken depending on the answers to these questions, thus determining the path through the decision tree format. The flowchart identifies the information required and the order in which it is needed. Indirectly, it also identifies information that is not needed.

10. The methodology described here is based on decision tree protocols where physically important characteristics are required to answer mechanistically based questions relating the causes of energetic materials reactions to the severity of such reactions.

11. Having the hazard protocols, the objective is to know what will happen when a munition or component is subjected to fire, projectile impact or some other stimulus. To determine the response of the munition a description of the munition and its environment as well as a description of the stimulus is required. This can be written as:

munition + environment + stimulus → response

12. When dealing with munitions, filled with energetic materials, responses can vary from no reaction to detonation. To have a complete description, the time at which the energetic material starts to react is required. Thus the response must be described as

- (1) when the material starts to react, and
- (2) what is the output, or violence of the reaction. Both are important and highly coupled.

For example, in some thermal environments if the energetic material reacts quickly (e.g. at some low temperature) the reaction violence may not be as severe as if the reaction initiated at some later time (and therefore higher temperature). The protocol methodology puts this question and answer process in a logical and systematic flow.

13. Both simplified and detailed protocols have been developed for Fast/Slow Heating, Bullet/Fragment Impact, Shaped Charge Jet Impact and Sympathetic Reaction. The simplified protocols are an introduction to the individual hazard areas, and provide an overview of the mechanistic considerations particular to each hazard. The detailed protocols present a comprehensive view of the mechanisms and how they are coupled together, along with a discussion of the underpinning science.

14. The protocols are accompanied by tables providing examples of tests and techniques that can be used to answer the questions posed in the decision tree. These tables are neither exhaustive nor exclusive, and users of the protocols should seek to use the most up to date and well validated tools available to them. Examples of tools and techniques that can be used are:

- Read across from similar designs.
- Modelling and analysis.
- Energetic materials characterisation.
- Laboratory scale test results.
- Small scale and component level test results.
- Full scale test results.

15. Although some flowcharts are long and quite complex, a specific application of a specific hazard scenario generally only uses a small segment of the complete protocol. The level of detail needed for an assessment may be related to the stage of the munition project, and either the simplified or detailed protocols may be appropriate, or some combination or modification of either. For example, at the earliest stages of a munition's design a simplified protocol may be sufficient to reveal the benefits of using a low explosiveness, DDT resistant main charge explosive, whereas a detailed protocol may be required to determine the likely reaction of a complex rocket motor using one or more mitigation devices. In any case, when an assessment is made the protocol used to make it should be documented.

(a) Notes on the Protocols

- The response(s) of a munition to a stimulus may be determined using the decision process outlined in the appropriate protocol.
- Any suitable method may be used to answer the necessary questions, but the method and data used, together with confidence in the decision should be recorded.
- All behaviour should be predicted allowing for the range of temperatures, pressures and dynamic conditions that may apply.
- The potential reactions of all of the energetic materials in the munition must be considered.
- The level of detail used should be appropriate for the stage of the munition development and for the complexity of that munition.
- The response(s) determined from the decision process give the NATO response descriptor for the munition on the basis of the EM behaviour in the munition configuration. The potential hazard from the response must be determined from knowledge of the amount and type of EM reacting, its rate of reaction, and the munition design.
- The tables accompanying each protocol give an indication of the type of evidence that should be provided to support an IM assessment.
- The protocols may be used in an iterative manner to establish the sensitivity of the assessment to variations in threat stimulus level, energetic material formulation, munition design, and packaging/storage configuration.
- The protocols may be used to evaluate the effects of time and temperature on the response of the munition. For example, the toughness of a cast cured PBX will change in the period before it is fully cured, and may change further as it ages. This may lead to a change in the response of the explosive to some or all of the IM stimuli.
- Managers of projects and programmes can use the protocols throughout the program to determine what design issues need to be addressed.

- Munitions designers can use the protocols as a tool to select appropriate materials and design features.
- Technology leaders can identify what technologies are important in the development of insensitive munitions.
- Technical specialists can show potential sponsors where their work fits in and why it is needed.
- Review Boards and National Authorities can use the protocols as a matrix to assure themselves that all relevant factors have been considered.

ASSESSMENT OF FAST/SLOW HEATING

Overview

1. Heat is a significant threat to munitions in general and represents a real hazard to energetic materials. Under some conditions a very rapid release of chemical energy can result in deflagration, thermal explosion or detonation of a munition.
2. While a very wide range of thermal environments are possible in hazard situations, in general these are simplified to two generic categories that are broadly representative of the extremes:
 - a. Fast Heating – Representing a munition completely engulfed in a hydrocarbon fuel fire such as that resulting from an aircraft crash on a ship or road transport accident. Typically fast heating is represented by fires with temperatures exceeding 800°C lasting up to twenty minutes. This scenario is also known as Fast Cook-Off.
 - b. Slow Heating – Representing heating of a munition by a remote heat source such as a fire in an adjacent compartment or building. Typically slow heating is described by a constant heating rate of 3.3°C/hour until the munition reacts. This scenario is also known as Slow Cook-Off.
3. The science of fast and slow heating is the same, as are the mechanisms that have to be considered, so a single protocol – either simplified or detailed - serves for both extremes and any intermediate heating condition that may be encountered. The simplified and detailed protocols are given at Figures C-1 and C-2.
4. Table C-1 identifies tests and tools that are pertinent to each of the decision points in the protocols and the materials properties data required to assist in the modelling or prediction of the results of such tests. Table C-2 gives examples of tests that can be used to determine values for the properties identified in Table C-1. These tables are neither exhaustive nor exclusive, and users of the protocols should seek to use the most up to date and well validated tools available to them.

The Simplified Fast/Slow Heating Hazard Protocol

5. The simplified protocol in Figure C-1 presents the hazard assessment protocol logic in a form that captures the overall response mechanisms. It combines the individual steps assuming that, given certain conditions, the overall mechanism will determine the response.
6. When applying the simplified protocol, the following should be considered:
 - a. The time to reaction should be modelled allowing for the insulating effects of any packaging around the munition being assessed.
 - b. De-confinement in this context relates to weakening of the munition case materials (due to combustion, melting, softening and/or thermal expansion) so that EM/liner pyrolysis or combustion products can vent at or close to atmospheric pressure.
 - c. The possibility of movement of the EM subsequent to melting or softening and pressure induced flow should be considered.
 - d. The assessment of the mode of burning of the EM should be made across the appropriate pressure and temperature ranges. In this context, normal surface regression implies that there is no convective burning and no additional burning surface due to cracking or pyrolysis of the EM.

- e. If EM combustion products are expected to vent through holes or cracks in otherwise intact munition cases, the possibility for propulsion must be considered. Potential thrust can be predicted using suitable propulsion codes together with the burning parameters of the EM's potential burning surface and vent areas.
- f. Assessment of whether a deflagration to detonation transition (DDT) is possible should be made using EM in the worst state that may be expected within the munition being assessed (purity, porosity, temperature and initial pressure).

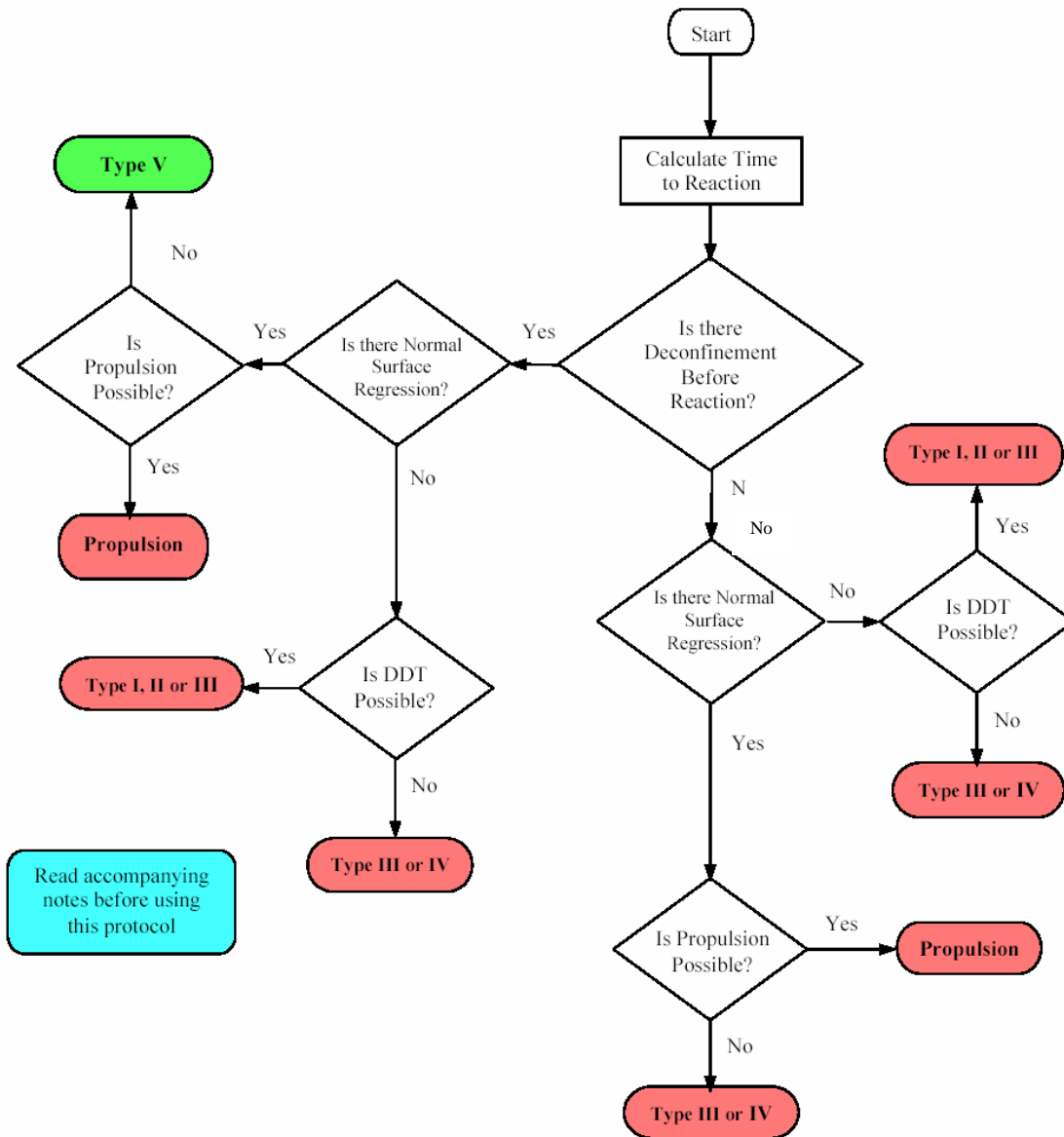

Figure C-1 Simplified Hazard Protocol – Fast/Slow Heating

The Detailed Fast/Slow Heating Hazard Protocol

7. The detailed protocol in Figure C-2 considers each step in the sequence of events leading to some response, and examines the details of each mechanism. It contains seven major portions. These are:

1. Initial thermo-chemical system description
2. Thermo-chemical/thermo-mechanical system description and their response to new boundary conditions (i.e. time steps and thermal variation.)
3. Self sustained exothermic reaction.
4. Evaluation of burn criteria with the possibility of thermal explosion.
5. Evaluation of the confinement and its effect on the reaction.
6. Evaluation of the status of the energetic material.
7. Change in the thermal loading and its effect on the system.

8. A technical description of the protocol is given for each box according to the number indicated in Figure C-2:

Box 1: Initial Thermal System Description

B1.1 Weapons can be damaged by thermal stimuli. In order to adequately evaluate the response of a munition to a specific thermal threat, one needs to define the necessary initial input parameters. For many systems, a large amount of data is needed to have a predictive capability. These input conditions include:

- a. Weapons geometry - complete with munitions case dimensions, thickness, insulating materials, liners, stress release systems etc.
- b. Chemical and mechanical properties of all components, ie heat capacity, conductivity, density, thermal expansion, modulus, elastic modulus, yield strength, phase changes, temperature and pressure dependent kinetics of energetic materials, burst pressure of each case (system specific) and rate dependent kinetics - spanning multi-step Arrhenius kinetics for specific formulations, all as a function of temperature. The initial input parameters must be sufficient to describe all subsequent modified thermal profiles of the system. Data is required as a function of temperature over the temperature range of interest. Such data includes thermo-mechanical/ thermo-chemical changes, case rupture etc.
- c. Initial temperature profile, especially in the energetic materials. As fairly high temperatures would be achieved, a thermo-chemical description of all energetic materials present is required. For example, an investigation could include the propellant (rocket or gun propellant) and its ignition system, as well as the explosives in the warhead, and its initiating components. Basic data required for such evaluations will include chemical descriptions of all energetic material components in the high temperature conditions identified. Temperature and pressure- dependent decomposition kinetics and energetics of these materials are still being developed. This is an area where a significant effort is required to setup a valuable database.
- d. Description of the target - size, geometry, components, and confinement (including self-confinement) needs to be considered.

B1.2 In addition to the data mentioned as the initial thermal/mechanical system description, other information, such as these arising from the following questions, are required:

- What are the materials used?
- What are the components with EM's?
- What mitigation devices are included?
- Where is the system? Why is the system vulnerable?

- What data do you need to proceed?
- Which other variable do you need to know?

Box 2: Heat Source

B2.1 The description of the heat source is obviously a necessary first step, since it is the definition of the stimulus. This description must include:

- a. The Energy Source
 - If it is a fire, then what is the combustible: fuel, oil, wood, other combustibles?
 - If it is indirect heating, is it caused by:
 - An adjacent free fire?
 - A fire in the compartment separated from the target system?
 - Other possible energy sources include:
 - Impingement of exhaust from a "huffer": (aircraft starter blower) or from an adjacent aircraft exhaust
 - Impingement of the exhaust from a rocket motor or torching from a damaged rocket motor or warhead.
- b. The Environment
 - Is the target in a confined or unconfined space?
 - If it is unconfined, is there an air flow across it, either due to wind or the motion of the fire?
- c. Situational Aspects
 - Are there any aspects of the source situation that need to be considered?

Box 3: System Specifics

B3.1 To make realistic predictions the cook-off protocol must include system specific parameters, both initially and at each time step. For example, the munition (including its storage container or conditions) may impose specific preferential heat flow paths into the energetic material, so that local intense heating sufficient to cause rapid decomposition can result. Alternatively, thermal batteries, boosters, igniters etc, may preferentially ignite, or ignition of a rocket propellant may occur through the nozzle of a rocket motor.

B3.2 Furthermore, after a certain time interval some conditions could have changed significantly and new information, such as these arising from the following questions, would be required:

- Has the overall geometry fundamentally changed?
- Have things come apart, moved or changed position?
- Has something happened that changes the models of heat transfer?
- Which components are now critical?

B3.3 No protocol can address all possible combinations and permutations of munition assemblies. It is, therefore, the assessor's responsibility to determine if there are any assemblies which could affect the response of a munition.

Box 4: Heat Transfer to the Target System

- B4.1 The next step, once the heat source has been thoroughly characterised is to describe how the energy is transferred from the source to the munition, through conduction, convection and/or radiation. This is a necessary, but difficult task, usually done by analysis. The analysis is complicated by many unknown properties and the need to make assumptions. These assumptions often determine the answer and, hence, it is vital that they are clearly stated.
- B4.2 The result of the heat transfer analysis is a description of the energy flow to the target and a description of the thermal response of the target. This thermal response is usually described in terms of temperature-time-position profiles in the target munition.

Box 5: Temperature-Time-Position-Profiles

- B5.1 If the temperature gradient is very low, not much heat is being transferred into the munition, and if the time is not excessively long, the energetic material remains at some low or modest temperature, and usually no event occurs. This is the desired result, but unfortunately many situations do not yield to these low temperatures.
- B5.2 The protocol assumes the worst case, in that heating of the system can eventually lead to a fully sustained exothermic reaction in the energetic material.
- B5.3 Fast heating rates, associated with a munition in a fuel fire or subjected to hot exhaust gases or the effects of torching, usually produce steep temperature gradients within the munition causing rapid heat transfer into it and resulting in parts of it attaining very high temperatures. This is the so-called fast cook-off regime.
- B5.4 On the other hand, slow cook-off regimes or heating, which produce low temperature gradients in the weapon but are applied for long periods of time, can bring the bulk of the item to a relatively uniform high temperature, as opposed to the steep gradients characteristic of fast cook-off situations. This slow cook-off regime often produces violent events, because ignition tends to occur within the bulk of the energetic material and the chemical decomposition is accelerated by self-confinement and by adjacent hot materials.
- B5.6 Fast cook-off regimes, by contrast, may lead to lower intensity events, because ignition occurs near the case/energetic material interface and the case may lose its structural integrity early. However, it must be noted that, for intermediate heating rates, reaction violence is a function of where initiation occurs.
- B5.7 The process for evaluating the response of a munition to cook-off is iterative, requiring several separate reviews of the thermo-mechanical environment during the evolution of the thermal environment until a reaction occurs, or it is clear that it cannot.

Box 6: Thermo-mechanical/Chemical Response

- B6.1 On the initial pass through the protocol, the thermo-mechanical/chemical response may be confined to a simple appraisal of the design and its relationship to its surroundings. This should be sufficient to indicate whether the case will be ruptured before there has been any appreciable heat transfer to the interior of the munition. For example, is the case fitted with any thermally initiated mitigation devices? What is the case material? It is fabricated from homogeneous metal, composite/metal/non metal, or composite/non-metal/non-metal? Are there any stress risers etc? On subsequent passes through the protocol, the effects of temperature on the thermo-mechanical properties will need to be taken into account for all energetic and non-energetic materials affected by heat.
- B6.2 As fairly high temperatures will be achieved; a thermo-chemical description of all energetic materials present is required. For example, such an investigation would include the propellant (rocket or gun propellant) and its ignition system, in addition to the explosives in the warhead, including its initiating components. The basic data required for such evaluations will include

chemical descriptions of all energetic material components under the high temperature conditions identified. Temperature and pressure-dependent decomposition kinetics and the energetics of these materials is required.

- B6.3 The thermo-mechanical description is also required to assist the determination of $T = T(x,T)$ and identify the effects of phase changes and chemical reactions, e.g. pyrolysis. These will give system pressurisation rates, changes of thermal insulation effects etc. In some cases, chemical reactions produce significant changes in the properties of materials, e.g. intumescence as a result of charring. The basic data required for such evaluations will include the heat transfer characteristics of the case and chemical descriptions of all materials used, such as adhesives, insulants, energetics etc. A check must be made to determine whether or not pyrolysis products rupture the case (for example: composite cases, mitigation case devices etc).

Box 7: Is There a Self Sustained Degradation?

- B7.1 On the initial pass through the protocol, the temperature may be too low to cause any exothermic reactions. On the subsequent passes where time intervals are added, substantial material property changes may have occurred due to the temperature rise. A re-evaluation of the thermo-mechanical/chemical response could indicate that the temperature has increased enough that an exothermic reaction could become possible. Such reactions need to be considered as it could result in self-sustained reactions, particularly when rather slow temperature rises are applied. In the presence of such a reaction, the next step on the path is to check to see if there is a burn. Without a self-sustained reaction, this could indicate the end of the thermal event.

Box 8: Is it the End of the Thermal Event

- B8.1 At this point, the protocol user has to ask questions such as:
- Has a steady state (or certainty thereof) been reached?
 - Can no reaction be worse than burning, assuming things continue?
 - Is everything either going to be consumed or cooled off? As an example, the thermal threat may cease or the temperature could stop increasing before the point of a self-sustained exothermic reaction is achieved.
- B8.2 If the end of the thermal event is not indicated, the protocol continues with the next time step. If the end of the thermal threat/event is determined (a yes answer) no new reactive response need be considered. Despite the fact that there is no new response, the user should note that there may be residual damaged materials which could be more sensitive than the initial materials. The system is at a steady state, or cooling condition, and it does not propagate to a runaway reaction without further stimulus.

Box 9: Is There Burning?

- B9.1 Ignition is the beginning of every combustion process.
- B9.2 On the initial pass through the protocol, the temperature may be too low to cause ignition. On subsequent passes, where time intervals are added, the temperature will increase and an ignition could become possible. The question that needs to be asked is: are there ignition mechanisms other than those from pyrolysis products? The energetic materials may reach their ignition temperature by thermal/chain-thermal branching reactions, or as a result of impinging flames after some damage to the case or its closures.
- B9.3 These investigations of ignition must also include system specific considerations. The munition, or its storage container or conditions, may impose specific preferential heat flow paths into the energetic material, so that local intense heating, sufficient to cause rapid decomposition, could result. Alternatively, thermal batteries, boosters, igniters etc may preferentially ignite, or ignition of a rocket propellant may occur through the nozzle of a rocket motor.
- B9.4 A pressure burst of the case can occur without a significant reaction of the energetic material. The latter may even ignite later in an unconfined state. However, if the pyrolysis products are able to escape and eventually attain their flash point, this could lead to ignition of the free surface of the energetic material.
- B9.5 The process called thermal explosion or self-ignition, takes place at relatively low heating rates. Uniform heating of the sample occurs. Heat accumulation in the system occurs largely due to internal sources. Self-acceleration of chemical reactions after failure of the thermal equilibrium with the ambient medium takes place simultaneously throughout the volume and is of homogeneous explosive nature.
- B9.6 A self-sustained exothermic reaction in absence of burning can produce a violent reaction such as a thermal explosion. Such a reaction can even transition to a detonation, referred to as thermal explosion to detonation transition (TEDT). If no thermal explosion occurs, the path goes back to another time step.
- B9.7 Where does ignition occur in the interior of the energetic materials? Evidence exists from many experimental/theoretical sources that the location of the ignition point is a direct outcome of the heating rate, system size, geometry, thermo-mechanical properties, and construction. For smaller munitions, slow heating or slow cook-off as defined as a heating rate of 3.3°C/hr applied to the outer surface of the system, may result in central ignition. In general, ignitions occurring within the body of the energetic material have at least some tendency towards self-acceleration due to self-confinement, and ultimately, catastrophic reaction, such as detonation. Indeed, it has been shown experimentally that cook-off of bare charges can, in some instances, lead to detonation.
- B9.8 Faster heating rates, such as those experienced when a munition is placed in a fire, usually results in a self-sustained exothermic reaction of the energetic material occurring at or very near the energetic material/case interface. Sometimes the confinement is released before the reaction can build-up to detonation. However, if the confinement is sufficient, this can, and often does, lead to a violent reaction, such as a detonation.

Box 10: Significant Confinement

- B10.1 If there exists a self-sustained exothermic reaction with combustion, one needs to determine if the reaction will propagate to a detonation or a lesser violent reaction. This can be evaluated by the degree of confinement the system is subjected to. For example, if the reaction is in the centre of a highly confined bomb, it will likely transition to a detonation.
- B10.2 However, if you have a reaction initiating in the centre (near the bore) of a lightly contained composite rocket motor, you may not have Deflagration to Detonation Transition (DDT). A second example occurs if the burst pressure of the case is exceeded, in which case there is not enough confinement to cause a reaction greater than propulsive. It is very important to consider the design of the munition casing. An investigation is required to demonstrate if the case will or will not rupture before appreciable heat transfer has occurred in the munition to reach a temperature high enough to cause some decomposition of the materials, energetic or inert. For example, is the case fitted with any thermally initiated mitigation device such as stress risers, composite materials etc? When such devices are present, the case would normally open before a reaction of the energetic materials has built up and a mild reaction is probable. Without thermally initiated mitigation devices, the user has to do a complete thermo-chemical description of all energetic materials.
- B10.3 Do pyrolysis products cause rupture? It has been established that pyrolysis products can influence the failure mechanism of munition in fuel fires. If pyrolysis products are generated between the case and energetic material, say from the decomposition of an insulator, and these products are unable to escape, a localised increase in pressure will be generated. This pressure may cause the energetic material to be damaged, or it may lead to the rupture of the case. However, if the pyrolysis products are able to escape, and eventually attain their flash point, they could lead to ignition of the free surface of the energetic material. It may be that the pressurisation is the result of effects in something other than the energetic material and a pressure burst of the case could occur without significant energetic material reaction. The latter may even ignite later in an unconfined state.
- B10.4 If there is burning without significant confinement then the assessor must determine if the reaction goes propulsive. In the absence of a propulsive event the assessor must answer the question: Is there any EM left? Without a significant quantity of unreacted energetic material, the final result will remain a burn only. However, when there is a separated energetic material charge or a significant quantity of EM left, the protocol continues.

Box 11: Is DDT Possible?

- B11.1 A self-sustained exothermic reaction or a burn in the presence of significant confinement could degenerate to a detonation, referred to as a deflagration to detonation transition (DDT). When no DDT can be identified, the protocol user must check to determine if an explosion or a propulsive event is possible prior to investigating the possibility of some energetic material left.

Box 12: Time Increments

- B12.1 The selection of time intervals appropriate to the munition under review will require an appreciation of the mechanical and thermo-mechanical characteristics of the system. This must be reflected in the choice of the time step.

Box 13: Change Thermal Loading

B13.1 Has the thermal loading changed significantly? For example, have new heat sources been introduced either by the weapons subsystems or any adjacent weapons? Has the geometry been changed such that the heat flux to the weapon has changed? Has the insulating barrier been destroyed? "Yes" leads to reevaluation of the heat source. "No" leads to a continuing modification of system specifics.

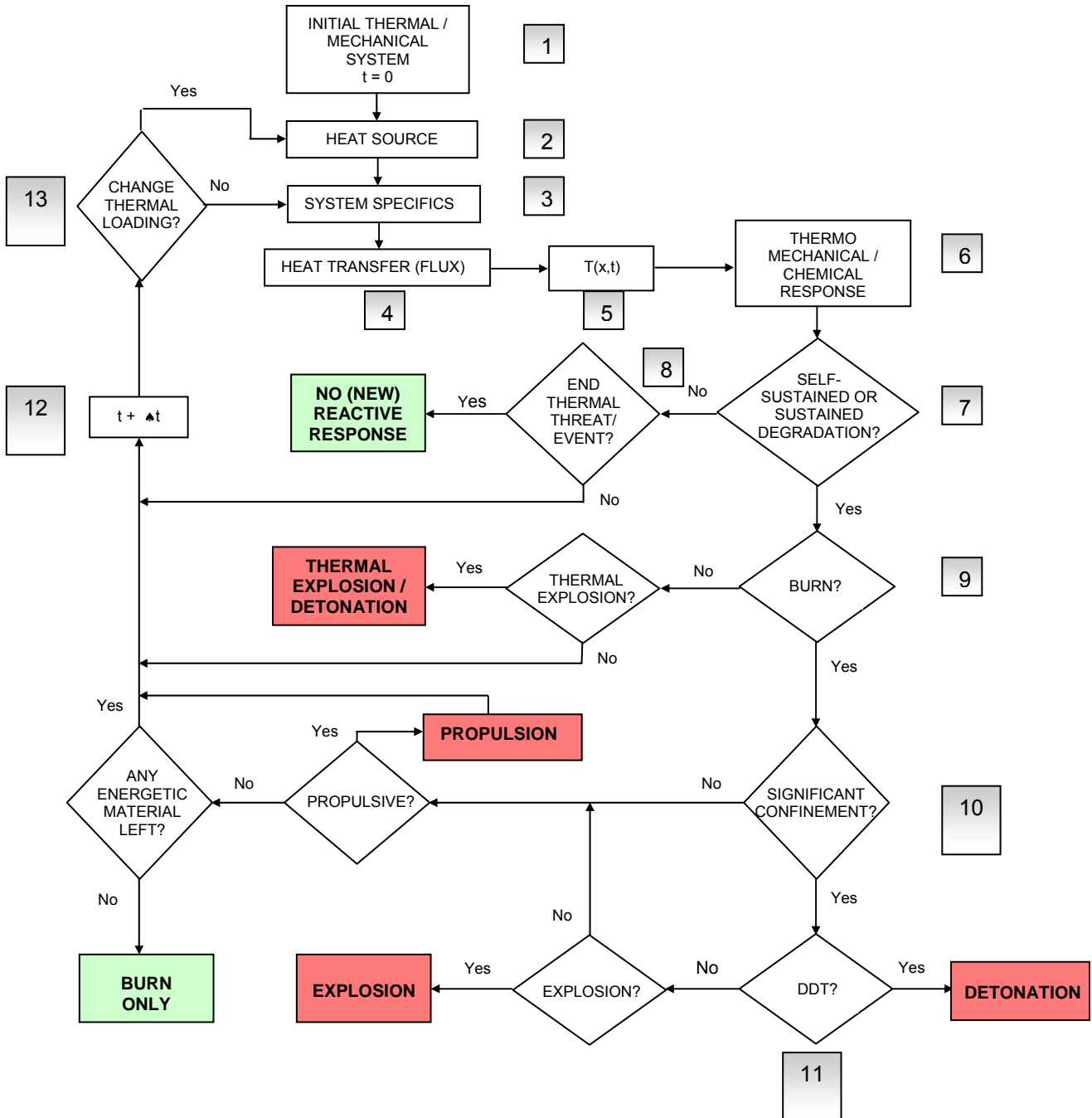

Figure C-2 Detailed Hazard Protocol – Fast/Slow Heating

TABLE C-1 Examples of tools available and data required to analyse fast/slow heating reaction paths

KEY FACTORS/ REACTION MECHANISMS	TOOLS FOR ANALYSIS	PROPERTIES REQUIRED
Time to ignition	Thermochemical Limits Test (TLT) Ignition Temperature Test Unconfined Thermal Ignition Test One Dimensional Time to Explosion (ODTX) Differential Scanning Calorimetry (DSC) Thermogravimetric Analysis (TGA) Accelerated Reaction Calorimetry (ARC) Reactive Heat Flow Models	Kinetics and thermochemistry of EM Decomposition as a function of temperature and pressure Thermal properties of munitions EM Thermal properties of munitions inert individual components Extrapolation of the above to munition full size dimensions Detailed munitions design Damage dependency
Effect of Confinement on Energetic Material Reaction	Thermo Analytical Techniques Finite Elements Analysis Models Computational Fluid Dynamics Models Effect of Confinement on EM Reaction Variable Confinement Cook-off Test (VCCT) Tube Test (Fast/Slow Heating Versions) Hot Cell Pyrolysis Test Scaled Thermal Explosion eXperiment (STEX)	Mechanical physical and thermal properties of munitions EM Mechanical physical and thermal properties of munitions individual inert components Mechanical physical and thermal properties of munitions assembly and packaging Kinetics and thermochemistry of EM Decomposition as a function of temperature and pressure Mechanical and thermal properties of case, liner and EM Extrapolation to munitions full size dimensions Detailed munitions design
Burning	Closed Bomb (and Variations of) Strand Burner DSC	Mechanical physical and thermal properties of munitions EM Burning rate as a function of temperature and pressure Damage Dependency
Deflagration to Detonation Transition (DDT)	Tube Test, Internal Ignition Version UN Test Series 5 Hybrid Combustion Bomb Closed Bomb Run-to-detonation Distance (of Damaged Material) Critical Diameter Dynamic Case Resistance	Mechanical physical and thermal properties of munitions EM Burning rate as a function of temperature and pressure Damage dependency

KEY FACTORS/ REACTION MECHANISMS	TOOLS FOR ANALYSIS	PROPERTIES REQUIRED
Violence of Response	dP/dt Information Case Fragmentation Models	Burning rate as a function of temperature and pressure
Propulsion	Closed Bomb Strand Burner Ballistic Models	Burning rate Detailed munitions design

TABLE C-2 .Examples of tests that can be used to generate the data required in Table C-1

DATA REQUIRED	PROPERTIES	TEST TO BE CARRIED OUT	GENERAL POINTS
Kinetics and thermo chemistry of EM physical changes or decomposition	<ul style="list-style-type: none"> • Porosity • Pore size 	<ul style="list-style-type: none"> • Density Measurements • Refractive Matching Fluid • Atomic Force Microscopy • Scanning Electron Microscopy (SEM) 	<ul style="list-style-type: none"> • Over a suitable temperature, pressure, dimensions and geometries range including ones resulting from mechanical or/and thermal damages
	<ul style="list-style-type: none"> • Particle size • Crystal quality 	<ul style="list-style-type: none"> • Microsonic Techniques • SEM • Microscopical Techniques • X-ray Diffraction • Density measurement test 	
	<ul style="list-style-type: none"> • Chemical reaction rate 	<ul style="list-style-type: none"> • Adiabatic bomb calorimeter • Thermo analytical techniques <ul style="list-style-type: none"> • Differential Scanning Calorimetry (DSC) • Dynamic Mechanical Thermal Analysis (DTMA) • Thermo Mechanical Analysis (TMA) • Thermo Gravimetric Analysis (TGA) • Differential Thermal Analysis (DTA) • Dilatometry 	
Burning rate	<ul style="list-style-type: none"> • Burn rate (Undamaged and damaged material) 	<ul style="list-style-type: none"> • Strand burner • Closed bomb • Hybrid combustion bomb 	<ul style="list-style-type: none"> • Over a suitable temperature, pressure dimensions and geometries range including ones resulting from mechanical or/and thermal damages • Not measured routinely • Highly dependent on damage characteristics • Fractures • Porosity • Dewetting
	<ul style="list-style-type: none"> • Friability: Propensity to fracture/damage 	<ul style="list-style-type: none"> • Shotgun test (Friability test) • Bullet damage test • Hopkinson bar • Failure modulus test • Taylor impact test • Fracture toughness 	
	<ul style="list-style-type: none"> • Damage Characterisation 	<ul style="list-style-type: none"> • Sectioning microscopy • X-Ray tomography • Closed bomb (Surface area) • Neutron and X-Ray diffraction • Coefficient of Thermal Expansion 	

DATA REQUIRED	PROPERTIES	TEST TO BE CARRIED OUT	GENERAL POINTS
Mechanical physical and thermal properties of munitions individual inert components		<ul style="list-style-type: none"> • Thermal expansion measurements • Thermo analytical techniques <ul style="list-style-type: none"> • Differential Scanning Calorimetry (DSC) • Dynamic Mechanical Thermal Analysis (DTMA) • Thermo Mechanical Analysis (TMA) • Thermo Gravimetric Analysis (TGA) • Differential Thermal Analysis (DTA) • Dilatometry • Mechanical properties analysis <ul style="list-style-type: none"> • Uniaxial Tensile/Compressive Testing (Low Strain Rates) • Servohydraulic Mechanical Test (at rates from 1 to 500 /s) 	<ul style="list-style-type: none"> • Over a suitable temperature, pressure, dimensions and geometries range including ones resulting from mechanical or/and thermal damages
Thermal physical and mechanical properties of munitions EM		<ul style="list-style-type: none"> • Same as in Mechanical physical and thermal properties of munitions individual inert components • AOP-7 test category 102-02-xxx 	<ul style="list-style-type: none"> • Over a suitable temperature, pressure, dimensions and geometries range including ones resulting from mechanical or/and thermal damages
Mechanical physical and thermal properties of munitions assembly and packaging		<ul style="list-style-type: none"> • Same as in Mechanical physical and thermal properties of munitions individual inert components • Mechanical properties analysis <ul style="list-style-type: none"> • Hopkinson Bar (at Rates from 100 to 10⁴/s) • Components bond strength <ul style="list-style-type: none"> • AOP-7 Series 102.01 tests • Compatibility test in an environment representative of IM tests 	<ul style="list-style-type: none"> • Over a suitable temperature, pressure, dimensions and geometries range including ones resulting from mechanical or/and thermal damages
Detailed munitions design		<ul style="list-style-type: none"> • Technical Data Package • X-Ray • Munitions disassembly 	<ul style="list-style-type: none"> • Geometry and physical size • Loading density • External confinement • Gas tightness • Free volume • Casing type

ASSESSMENT OF BULLET/FRAGMENT IMPACT

Overview

1. Reaction of a munition to the bullet/fragment impact stimulus occurs because there is either direct shock initiation or ignition of damaged energetic material as the bullet passes through or lodges in the material.
2. While a very wide range of bullet and fragment impact scenarios are possible in hazard situations, typically they are represented by:
 - a. Bullet Impact - a 12.7mm AP bullet impacting at $850\pm 20\text{ms}^{-1}$.
 - b. Fragment Impact - a single 18.6 g steel fragment with a right-circular cylindrical body and a conical nose.
3. The principal factors affecting the response to such a stimulus are its shock sensitivity under confined conditions (Shock to Detonation Transition or SDT), the degree of confinement of the energetic material, the level of energetic material damage, the propensity for the energetic material to undergo deflagration to detonation transition (DDT), and the likelihood of transition to detonation resulting from a compression, release, recompression process as the result of a single initial stimulus (XDT).
4. The Bullet/Fragment Impact protocol is based on the idea that a munition will face a hierarchy of hazards when impacted by a bullet or fragment. The initial hazard, the shock generated during impact of the fragment or bullet on the munition, may lead to a prompt (and severe) response if shock criteria are satisfied. If not, then the munition may undergo a delayed response caused by interactions between the munition case and the energetic material. The protocol leads the user through this series of potential hazards and probable outcomes.
5. The science of bullet and fragment impact are the same, as are the mechanisms that have to be considered. Therefore a single protocol – either simplified or detailed - serves for both extremes and any intermediate condition that may be encountered. The simplified and detailed protocols are given at Figures D-1 and D-2.
6. Table D-1 identifies tests and tools that are pertinent to each of the decision points in the protocols and the materials properties required to assist in the modelling or prediction of the results of such tests. Table D-2 gives examples of tests that can be used to determine values for the properties identified in Table D-1. These tables are neither exhaustive nor exclusive, and users of the protocols should seek to use the most up to date and well validated tools available to them.

The Simplified Bullet/Fragment Impact Hazard Protocol

7. The simplified protocol in Figure D-1 presents the hazard assessment protocol logic in a form that captures the overall response mechanisms. It combines the individual steps assuming that, given certain conditions, the overall mechanism will determine the response.
8. When applying the simplified protocol, the following should be considered:
 - a. The possibility of impacting bare EM must be considered when either there is separation between the case wall and the EM or where there is a central bore.
 - b. In this context, a “Bore effect” also called “Finnegan effect” can be observed when a debris bubble is impacting the second layer together with the projectile.

- c. "Layered burning of EM" refers to the possibility of rapidly accelerating convective burning occurring at any time during the combustion of the impact damaged and confined EM.
- d. In lightly damaged hardware with a small vent area, the possibility of a well behaved burning response of the EM generating sufficient pressure to violently burst its confinement must be considered.
- e. If EM combustion products are expected to vent through holes or cracks in otherwise intact munition cases, the possibility for Propulsion must be considered. Potential thrust can be predicted using suitable propulsion codes together with the burning parameters of the EM's potential burning surface and vent areas.

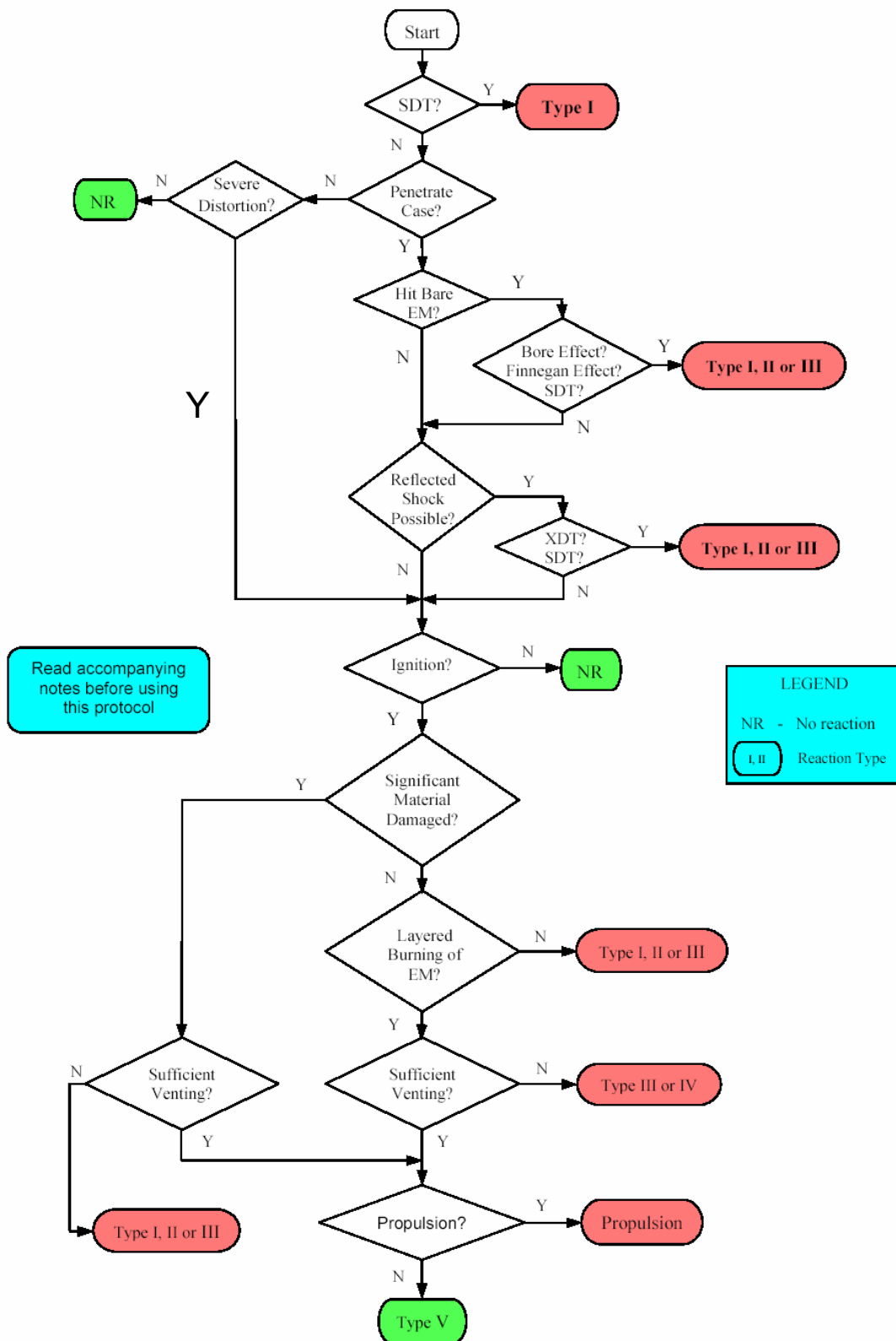

Figure D-1 Simplified Hazard Protocol – Bullet/Fragment Impact

The Detailed Bullet/Fragment Impact Hazard Protocol

9. The detailed protocol in Figure D-2 considers each step in the sequence of events leading to some response, and examines the details of each mechanism. The general philosophy behind the protocol is that there is a hierarchy of hazards faced by a munition impacted by a bullet or fragment.

10. The first hazard is the shock generated on impact. If it is transmitted to the charge, and shock criteria are satisfied, the response is prompt and, in most instances, severe. Failure to shock initiate the charge then leads to the possibility of a delayed response caused by the interaction of the case and/or projectile with the energetic material. The main interaction is a mechanical working of the energetic material by a rapidly distorting case, or by the penetration of the projectile. A lesser hazard under these circumstances appears to be the conduction of heat from fragment or case to the charge. The level of response to the charge distortion can vary from a mild burn to a severe explosion, depending on a number of variables which will be discussed more fully in the following notes.

11. For multiple fragments or bullets (with sequential rather than simultaneous impacts) it is possible that the first impact will not cause a severe reaction, but create sufficient damage to ensure that subsequent impacts will obtain a different response. Under these circumstances it is necessary to take account of the cumulative damage to the munition when attempting to predict the response to the next impact. Again these factors are discussed more fully in the following notes.

12. The flow chart which represents the hazard protocol shows the outcome of various types of impact. It is important to realise that these outcomes are probabilities – *not certainties*. In the shock initiation regime, for example, small changes in the loading density or composition of an explosive can create large differences in the shock sensitivity. This is almost certainly true in other areas, e.g. a charge damaged in transit to a military store may be more susceptible to ignition by case distortion than one carefully prepared for response testing. Consequently, however thoroughly a munition is tested, the above statement should be borne in mind.

13. In addition it will be seen that many areas of this protocol do not have quantitative predictive models. In its present form the protocol is intended to give a largely qualitative view of impact hazards. Where quantitative models exist, they should be used with caution.

14. In the following notes the term case is used as a generic description of case/liner/inhibitor/barrier; charge is used to describe any energetic material such as explosive or propellant; and any complete system containing a charge is referred to as a munition (this includes rocket motors). Fragment is used to denote any inert projectile impacting a munition (excluding shaped charge jets which are treated separately). Explosive bullets are not considered.

Notes (N) on the Detailed Protocol

N1. System Initial Conditions

Fragment Information

a. Distribution in space and time.

For multiple fragments, the effects of both simultaneous and sequential impacts have to be considered.

For simultaneous impacts the chances of two or more fragments being close enough to reinforce each other is usually small. Consequently the first fragment considered by the protocol is either the first to impact or the largest striking surface of those impacting simultaneously. The latter decision is based on the probability that this fragment will impart a greater volume of shock to the charge and increase the chance of a prompt initiation. If this fragment does not cause shock initiation, then none of the others should. Consequently each of the simultaneous impacts can be examined in turn to see if a delayed reaction is created. To a first approximation each will see an undamaged charge (if this is the first cycle through the protocol), but the possible vent area (see N17, N18, N20 & N34) will be from the sum of the impacts.

A possible exception to the reinforcement statement made above is for projectiles in the form of strips to impact simultaneously (possibly from a bomb casing). Some computer modelling shows the reinforcement of shock from impacts at relatively wide spacing. In turn this enhances the likelihood of shock initiation, and so the effective fragment is larger than any individual fragment when considering shock criteria. Hence projectile geometry is a factor when considering the effects of simultaneous impacts.

The effect of sequential fragments will depend on the delay between impacts and the displacement between impact sites. The delay will determine how much damage is done by the previous fragment and, if previous impacts have created inadvertent propulsion of the munition, will partly determine displacement of the impact. The lateral spread of fragments will determine the degree of damaged material encountered by the projectile (see also N11, N15 and N32).

b. Fragment properties.

The trajectory and speed of the fragment are important in determining the subsequent response. The trajectory determines which part of the munition is to be impacted, and hence fixes many of the geometric factors discussed below, and in N3-N7 and N17, N18. Both the obliquity of the impact and orientation of the fragment, as well as the velocity, have an important bearing on the ability of the projectile to transmit a shock to the charge, and to distort or penetrate the case. Other factors include fragment surface shape (e.g. certain cones and irregular fragments have little chance of generating strong shocks) and length, and the homogeneity of the fragment (density gradients and fragment cohesion). The Hugoniot is needed for shock calculations and the strength for penetration predictions.

Munition Information

c. Case

The number and type of layers determines both shock transmission and penetration/distortion. A Hugoniot and strength factors should be known for each layer together with the effective thickness presented to an impacting fragment. The curvature of the case and air gaps between the layers could have an effect on the focusing and amplitude of transmitted shocks. Even relatively thin layers could play an important role, especially in shock initiation. It is possible, depending on the Hugoniot of fragment, case and charge, for certain cases to apparently increase the sensitivity of a charge to shock initiation.

A previous impact can change the Hugoniot (e.g. by changing material porosity), the strength (work hardening or failure zones) and the geometry of the case. This could affect both shock transmission and penetration/case distortion. The presence and width of any air gap between charge and case must be established. This will affect shock transmission (see N3-N7, N25), and could affect the penetration of the case (see N17, N18) and the mode of case failure (see N23). In addition such a gap may allow fragments of case or the projectile to strike what is effectively bare explosive, increasing the chance of shock initiation (N26) Such an impact would have to take account of case material ahead of the fragment (whether it is in contact with the fragment, what impedance mismatch there is, what velocity and shape it is if it is detached from the fragment). Any changes in velocity, geometry and equation of state of the fragment have to be found in order to calculate the shock produced, and subsequent penetration if shock criteria are not satisfied.

d. Charge

The material properties include the Hugoniot for shock transmission, and strength characteristics for resistance to penetration and ease of charge break-up (important in determining growth of reaction after non-shock ignition, see N34). Geometry is important both for delayed reactions and for small (or thin) charges, where either run-to-detonation (see N3, N5) is not satisfied, or reflections off a rear wall increase the shock level in the charge to the point where shock criteria are satisfied. Both charge dimensions and configuration are factors in the above (see N32 for further comments).

The sensitiveness of the charge corresponds to the ease which a chemical reaction can be triggered (ignition), and is of importance in delayed reactions. Shock sensitivity (prompt reaction) depends on porosity, grain size (mainly for explosives), web size (for propellants), critical diameter (propellants although some of the less sensitive explosives could also be affected) and ambient temperature.

A previous impact can change the Hugoniot and increase the shock sensitivity by introducing additional porosity through the break-up of the charge (providing the shock from that impact has decayed - see comment under N3). If a degree of chemical reaction has already been triggered, this could affect the sensitiveness of the charge to further impacts. Charge break-up could introduce additional burning surfaces to facilitate the growth of a DDT response (deflagration to detonation transition) triggered by one of the non-shock mechanisms (see N14, N20 & N34). Both the strength behaviour over a range of strain rates (work hardening, thermal softening and melt) and a fracture criterion are needed to predict the charge break-up.

If a munition has been damaged before the fragment impact (e.g. by being dropped, or thrown against a bulkhead by a blast wave), it is probable that the most important damage is to the charge (see above for possible effects). If an object penetrates the case in this pre-fragment phase, then in principle it should be treated as an impact in its own right.

N2. Failure Diameter of Charge

The diameter of the charge (D) needs to be greater than or equal to the failure (or critical) diameter (d_c) of the energetic material for prompt Shock-to-Detonation Transition (SDT) to take place.

N3. 1D Shock Initiation

A shock which has some volume of one-dimensional (1D) flow within it appears to be one of the most efficient initiators of energetic materials known. The response to such a shock is usually prompt and so only a small volume in the region of impact need be considered for a very limited time when attempting to understand shock initiation. Equally the material properties are relatively simple (Hugoniot for energy transfer and some global chemical reaction kinetics - which are far from simple but are usually "tuned" for a given set of experiments). Consequently this area is ideal for small scale testing and theoretical modelling. For this reason it is the best understood of all the areas on the flowchart.

If the charge is already shocked by a previous impact, but has not initiated, then subsequent shocks transmitted into the shocked material will encounter a reduction in shock sensitivity. This is due to the first shock closing up voids in the charge, and leaving less scope for hot-spots to form.

N4. Projectile Diameter

If the projectile diameter (d_i) is very much smaller than the critical diameter of the charge, prompt shock initiation fails and other mechanisms such as bow shock (see N23) come into operation.

N5. 1D Shock Criteria

A variety of empirical relationships exist in this region to describe the boundary between detonation and non-detonation. If the criteria are satisfied then detonation is the usual outcome.

However, for impacts onto bare explosives, spheres and some cones have shown a response which, although severe, falls short of full detonation. For explosives the initiation threshold has been described variously by:

- Critical Energy Criterion (for plates, rods and spheres, rods into cased explosives.
- P^nT (P = shock pressure, T = shock duration).
- Sometimes used as an approximation to Critical Energy with $n = 2$, sometimes as an independent criterion
- V^2D (V = impact velocity, D = projectile diameter) for rods and spheres.

All of the above rely on sufficient explosive being present to allow run-to-detonation to occur. For insufficient explosive the apparent shock sensitivity changes (see N1 d).

For propellants the web size, impact pressure and critical diameter are found to be important factors in a shock criterion. Hydrocode simulations are available which include a simplified description of the chemical kinetics and hot-spot growth. Such simulations usually have to be "tuned" using data from embedded gauges, or are based upon empirical observations such as the "Pop-plot" and in general should be used with care if operating away from the model's data base.

Basic measurements to determine shock sensitivity are the gap or fragment impact tests, and the critical (i.e. failure) diameter is obtained from a wedge or stepped cylinder test. The run-to-detonation is obtained from the Pop-Plot.

N6. Divergent Shock Transmission

A region of impact has been found in which the 1D shock is either not transmitted, or is not transmitted in significant amounts, but a prompt initiation is still experienced. This can only be induced in this time scale by the diverging shock, which is at a high level since this phenomenon has only been observed at high impact velocities.

N7. Divergent Shock Criteria

Unlike the 1D criterion, where for most instances detonation will follow once the initiation threshold has been achieved, more sophisticated reactive flow modelling is required to find the level of response which is ultimately obtained from a given stimulus. The response level is determined by the balance struck between release wave propagation and the speed of reaction growth once ignition criteria have been satisfied.

N8. Shock Collisions

Where the initial shock is not sufficient to trigger initiation, it is possible for the geometry of the charge to amplify the shock at later times. Two examples are,

- a. A cylindrical charge in a dense container such as steel. The shock reflects from the container wall and converges on the centre-line of the charge, giving enhanced pressures, much in excess of the original, at late times which caused a delayed detonation.
- b. A rocket motor where the shock runs both ways in the charge surrounding the bore of the motor and collides at a point opposite the original impact. Again enhanced pressures can be obtained leading to reactions which are not caused by the original shock.

N9. Enhanced Shock Criteria

As in N7, the criteria needed to predict the onset of reaction, and its subsequent growth, are more complex than for the 1D shock interaction. The shock collision, often at complex angles, needs to be simulated on hydrocodes using a very fine mesh to capture the transient peak pressures generated. Again sophisticated reaction growth models are required to obtain the final response levels.

N10. Shock Damage to Charge

If the charge is damaged due to the passage of the shock, this increases the possibility of subsequent ignition due to other stimuli such as penetration by the projectile. It will also alter the shock sensitivity for subsequent impacts, probably making the material more sensitive once the initial shock which has caused the damage has been released.

N11. Update Charge Properties

It should be noted that the descriptions of both the energetic and inert materials within the munition are constantly updated with time - both within a given cycle and between impacts. The types of possible changes are discussed in N1, N3 and N10. Where this box occurs in the flowchart, it is probable that the sensitivity of the charge to a range of stimuli will change - usually (although not always) making the energetic material more sensitive.

N12. Shock Entering Damaged Material

There is the possibility of a reflected shock, or a shock from another fragment which has impacted simultaneously, entering damaged charge material.

N13. Criteria for Shock Initiation of Damaged Charge

Similar problems exist to those of N7 and N9. Here the timing of the entry of such a shock into the damaged material will be important, since it is very likely, when considering the situations discussed in N12, that the damage will still be changing with time. Hence the geometry of the charge and the pattern of impact will be important in determining final response.

Also important is the fact that the sensitivity of the damaged material will also be changing, a factor that would have to be considered by any predictive criterion.

N14. Compression of Porous/Damaged Charge

In very porous or damaged charges there is the possibility that a compression wave (as distinct from a shock) could cause ignition by the production of heating due to the large amounts of plastic work associated with the compression of the voids, and the adiabatic heating of the trapped gas. In this instance it is only necessary to transmit a stress wave of sufficient amplitude into the charge rather than having to produce a shock. This is possible for lower velocity/thicker cases/smaller projectiles than needed for shock initiation. The large amount of surface area available for burning coupled with probable lack of an entry hole makes a fast reaction growth and its attended response (see N34) possible.

The factors required for such a condition are a large degree of porosity (e.g. propellant bed) or a high degree of damage without large scale dispersion of the energetic material. A theory is needed to predict the onset of chemical reaction, and the subsequent growth requires a description of the equations of state controlling the solid, solid and gas, and gaseous phases. Knowledge of the chemical reactions and heat transfer properties is also needed.

This process tends to give a delayed reaction, which in turn indicates that it may not be suitable for small scale tests since the time scale could allow conditions throughout the munition to affect the response.

N15. Charge already Damaged/Porous

If the charge is already damaged or porous it is probable that the dynamic element of damage growth/change discussed in N13 no longer applies. The sensitivity factors should have been set at the start of the cycle or in a previous cycle. Non-damaged or non-porous material is unlikely to undergo ignition due to compression mechanisms.

N16. Impacts into Covered Charges

For a non-frangible, uncovered, lightly-confined energetic material it is probable that such a charge will only undergo shock initiation and nothing else, in contrast to a heavily confined

bare charge where other degrees of reaction have been observed. The impact of a projectile into bare energetic material occurs in test vehicles or where there is an air gap within the munition (in which instance the impacting projectile can come from the protective casing as spall or a plug ahead of the main projectile).

N17. Possibility of Penetration Given the Projectile Velocity

On the flowchart the possibilities for penetration are evaluated by first asking whether the fragment velocity is sufficient to allow the fragment through the case.

The simplest theory for determining the ballistic limit is to equate the original energy of the projectile to the work done in causing failure in the case (for modes of failure see N23), plus the elastic energy introduced into the system. This assumes a knowledge of the failure mechanism (which is affected by the shape of the projectile), the distribution of elastic stresses and the behaviour of strength (which will provide the amplitude of these effects) at various strain rates in case and projectile. Such data (plus a failure mechanism for the projectile) is also needed for calculating the possibility of projectile break-up, which could have an effect on both case and charge penetration.

The theory is complicated by the fact that in most munitions the case is in contact with the charge. This will affect the stress waves in the system and so, possibly, affect the mode of failure. Also the charge provides additional inertial backing for the case. Hence a slug of case material, even when failed, may then take additional energy to move out of the path of the projectile.

N18. Possibility of Penetration Given Projectile Dimensions

Assuming that the velocity criterion is met, the size of the projectile is one of the main factors which will determine whether penetration is accomplished. Other factors are the densities of projectile and case, the strengths (and their behaviour at various strain rates) of these materials and the shape of the impacting surface of the fragment. The charge will also affect the degree of penetration by taking energy from the projectile during charge break-up, and also providing inertial resistance to the fragment's progress. If a mild reaction is triggered in the charge, this may also affect the projectile's progress (a vigorous reaction probably makes the subject academic).

As an order of magnitude estimate, the Bernoulli penetration depth (which only depends on the square root of the density ratio of case to fragment) gives the case thickness needed to defeat a projectile of a given length. However, the situation is complicated by the fact that at low velocities (which are the case in the bullet/fragment regime) strength is a factor in this penetration (the Bernoulli depth is an overestimate.) The case is often relatively thin, which means a greater possibility of failure (see above and N23), and it may be layered with air gaps, both of which will affect the penetration.

N19. Ignition without Ventilation of the Charge

For heavily confined charges, ignition due to case distortion, but without subsequent penetration, means that the lack of venting imposes little restriction on the growth of reaction (see N34). Consequently there is a high probability of a severe explosion. It should be feasible to use small scale tests to warn of the possibility of this condition, since ignition probably occurs near the site of impact. An investigation of a range of impacts using a representative case, but small amounts of charge, will show if ignition occurs at maximum case distortion (but below penetration). Although the response will not be modelled, an ignition at this point indicates the possibility of a problem with a larger charge.

N20. Possibility of Ignition

Probably the main source of ignition is the heating of the charge by plastic work. This is carried out by rapid charge distortion (which does not allow time for heat to dissipate) and includes adiabatic shear banding, pinching, compression and extrusion. There is also the possibility of the deposition of hot spall for munitions with an air gap between case and charge. The key to ignition is the amount of heat the above mechanisms can generate, and the ease with which the charge molecules can use this energy to start breaking up (measured by the sensitiveness of the charge).

The initial progress of ignition within the charge can be delayed by physical separation of the charge material, especially by the presence of cracks, or propagation of cracks produced by the impact.

Important factors in this process are the ambient temperature of the charge, and for propellants the strain rate adjusted glass-transition temperature. However, there is a need for a general theory to predict the onset of chemical reaction.

N21. Brittleness of Charge Material

A key factor in the growth of reaction from the initial ignition is the mechanical properties of the charge. Brittle charges can break-up to give large surfaces which encourage burning. Rubbery or pressed charges tend not to have this problem.

Consequently a brittle charge which has been damaged by case deformation, and for which no venting is available, has a high probability of generating a severe response.

N22. Damage to Charge

The degree of damage to the charge will affect its subsequent sensitivity to a range of stimuli - see N10.

N23. General Points on Ignition Due to Case Distortion

The projectile will penetrate the case (see N17, N18) but ignition is due to the initial case distortion. Ignition mechanisms are discussed in N14. However, the mode of case failure may affect the dominant mechanism. Failure may be due to plugging, petalling or spalling depending on the shape of the fragment's impact surface and the presence of an air gap.

The promptness of ignition and the speed of reaction growth (see N34) could assign an importance to the speed at which the projectile clears the penetration hole in the case. If this hole is blocked for long periods after ignition (and especially if the projectile is brought to a halt in the hole) it is possible that the lack of venting could increase the severity of response (see N19).

N24. Damage to Charge from Case Distortion

See N22.

N25. Air Gap between Case and Charge

The size of any air gap will, within certain limits, determine the speed and shape of any projectile crossing it. After penetrating the case, the projectile, and any associated fragments (see N16), will change velocity due to the low impedance of the air gap. This change takes a finite time due to the time taken by the release waves within the fragment to impart the changes in velocity throughout the projectile material. Velocity gradients set up by this process within the fragment will lead to alterations in shape and size.

Small air gaps will have a negligible effect on the projectile, although their effect on any shock transmission into the charge could be considerable - leading to significant shock attenuation. The fragment velocity will eventually stabilise for a large air gap, although any fragment dispersion will continue until impact on the charge.

N26. Projectile Impact on Bare Charge

After crossing an air gap, the projectile, or case fragments preceding it, will impact on bare charge. If the velocity is high enough a shock will be generated. This requires a re-examination of the shock criteria taking into account the changes that have occurred to the projectile and charge since the first scan of these criteria. The projectile in this instance is the material that first comes into contact with the charge, and so could come from the case.

The velocity, density, shape and distribution of such material will all have been determined by the impact of the original projectile into the case (see N17 and N18), and will be needed when estimating whether shock criteria have been met.

Equally changes to the charge during the cycle (damage, pit-shocking etc.) need to be taken into account when considering these criteria.

N27. Fragment Penetration of Charge

The velocity of projectile penetration through the charge determines the dominant mechanism by which reaction is started in the energetic material.

N28. High Speed Projectile Penetration

It is assumed that in this instance the penetration rate is above the sound speed in the charge and so a bow shock is formed. Such a situation lies within the shaped charge protocol.

However, if no violent reaction occurs it is worth noting that large scale charge disruption is probable, to which the comments in N29 apply on both the likelihood of further reaction from fragment impact, and the chance of vigorous reaction from fast moving, broken-up charge material.

N29. Charge Break-Up from High Speed Impact

If another impact does not occur within a very short space of time, it is probable that such an event will scatter the charge. A large scale charge break-up will tend to deny other impacts the opportunity of spreading a reaction through a large body of energetic material, and so lower the response.

However, three possibilities exist that, if satisfied, may raise the response level. The first has another impact at a time before the charge has become widely scattered. The charge in this instance merely appears to be damaged, increasing sensitivity. The second has the case remaining largely intact and containing most of the charge. Again the charge material could appear as being merely damaged. The third possibility is that a significant mass of charge material remains intact (although damaged) but is thrown at high speed against a solid object. This may induce a shock into already damaged material with a correspondingly increased sensitivity.

In all of the above, much depends on the circumstances of the munition break-up and the surroundings in which it occurs.

N30. Low Speed Projectile Penetration

The penetration is below the local sound speed and so no bow shock is formed. The compression wave which may form in front of the projectile is not an efficient mechanism for starting a reaction unless the charge is porous or already damaged.

N31. Low Speed Fragment Lodges in Charge

Ignition due to a low speed fragment is the same as discussed in N20, with the additional hazards of heat generated by pyrophoric fragments, heat from normal fragments and the possibility of additional heat flow from a fragment that breaks up.

Also such a penetration into a porous or damaged medium may set up a stress wave ahead of the projectile that satisfies the requirements discussed in N14, but with a vent hole which will lessen the chances of a severe reaction (see N23 for discussion on the situation where fragments block vent holes).

N32. Low Speed Fragment Passes through Charge

Ignition hazards are as for N31, but with less likelihood of fragment heat being a mechanism. One additional hazard is the possibility of pinching or crushing the charge between

the fragment and a back-plate. The increased venting (from entry and exit holes) may decrease the response (depending on the time scale over which reaction growth occurs). For a sufficiently massive fragment, the munition may break-up leaving little chance of other impacts creating a reaction.

However, there is a chance that broken-up (and hence porous) charge may be more susceptible to ignition and violent reaction if it is thrown at speed against a solid surface. This may happen if the case is split sufficiently or if there is a cavity or channel (especially one that is unlined) within the charge (such as in rocket motors). A projectile crossing such a cavity could cause a spall of charge material in front of it, or a spray of material behind it, either of which could be ignited by the stress wave formed on striking the far surface (see N14). Such an occurrence obviously depends on the geometry of the charge and the trajectory of the fragment through it.

For lightly confined frangible energetic materials there is a probability that, after fracture, subsequent shocks/compressions acting on the damaged material may cause initiation at lower thresholds than for the undamaged charge.

The break-up of the energetic material is principally caused by tensile waves, generated at free surfaces, damaging material in the body of the charge. The geometry of both projectile and charge is important in determining whether the projectile can generate a compression/shock in material that has been damaged by such a process, since the geometry will determine the time frame in which such damage can occur.

If XDT criteria are not satisfied, it is highly probable that the projectile will completely penetrate the charge, breaking it up and denying subsequent impacts (unless they are very close in time and sufficiently displaced from the first) the chance of initiation (but see also comments - particularly the second caveat - discussed under N29).

N33. Reaction Threshold

If no chemical reaction is triggered, then only mechanical damage to the munition needs to be accounted for before any further impacts are considered (see N11). If reaction is triggered, the level of response depends on factors discussed in N34.

N34. Growth of Reaction

This relates to the explosiveness of the material and can result in a wide range of responses from severe explosion (and possibly detonation) to mild burn. The main factors are the brittleness of the charge material (and hence its ability to easily produce large burning surfaces on fracture) and the amount of venting available which allows gas to escape and pressure to drop. A porous or damaged charge may fill the same role as a brittle one (see N14). The quantity of material present, the ambient temperature and the charge configuration (e.g. web geometry for rocket propellants) can also be important in determining the final response.

In general terms, a charge which is easily broken to form large surface areas and has little ventilation, is likely to undergo a rapid/sustained growth of reaction leading to a severe explosion. On the other hand a rubbery composition which deforms but is difficult to fracture, and has a large amount of ventilation, is likely to undergo a slow growth of reaction (or a growth that is quickly terminated) leading to a mild response. A variety of responses can be obtained for situations between these extremes, and a quantitative theory is needed to describe reaction growth. The major factors required are listed in N14. Small scale tests may not be applicable since the overall characteristics of the munition are important.

A projectile penetrating damaged/porous material will increase the possibilities of generating sufficient compression to ramp any reaction process into rapidly forming a shock and thence to detonation (XDT). Such a process causes a fast reaction growth.

N35. Mild Reaction

This could change the charge equation of state, sensitiveness and shock sensitivity to subsequent impacts. It could also change the penetration characteristics of the charge material and stress the case.

Inadvertent propulsion could change the charge orientation and position for the next impact.

N36. Further Impacts

For simultaneous impacts, the possibility has to be considered that another fragment impacting a different part of the munition may produce a higher response. This is applicable to non-shock mechanisms. See N1-a for the selection of the "first" fragment, and the degree of damage that will be seen by other simultaneous impacts.

Sequential impacts are more likely to produce a larger response from the munition because of damage already done to the charge. See N1-a. for a discussion of the factors involved.

N37. Finish

Although the immediate effects are small, with little in the way of blast and fragment production, some degree of burning is probable. When considering mass reaction in munition stores, it should be noted that this cycle produces the possibility of inadvertent propulsion of the munition under attack.

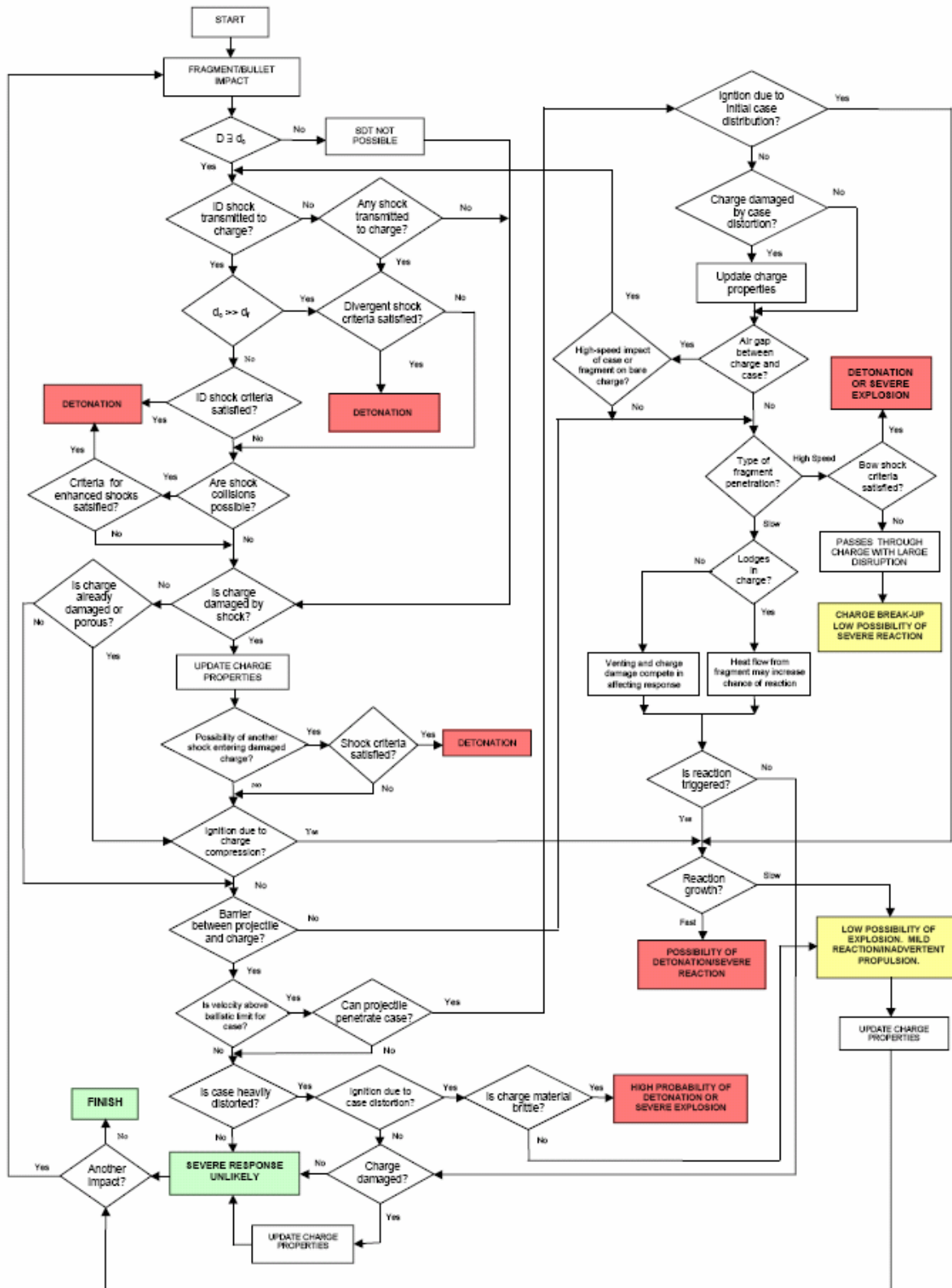

Figure D-2 Detailed Hazard Protocol – Bullet/Fragment Impact

TABLE D-1 Examples of tools available and data required to analyse bullet/fragment impact reaction paths

KEY FACTORS/ REACTION MECHANISMS	TOOLS FOR ANALYSIS	PROPERTIES REQUIRED
Shock to Detonation Transition (SDT)	Gap Test Wedge Test Critical Diameter Test Plate Impact Test High Velocity Shotgun Test	Scaling Effects Fragment Characteristics Shock Hugoniots of Energetic Materials and Impactor Shock Pressure and Duration Pop Plot Critical Energy Design Dependent
Penetrate Case / Severe Distortion	Mechanical Properties of Case and Projectile at High Strain Rate Projectile Physical Characteristics (Velocity, Geometry, Mass)	Mechanical Properties of Case and Projectile Geometry and Ballistics of Projectile Ballistic Limit for Case Projectile Break-up and Resulting Fragment Characteristics Design Dependent
Hit Bare EM	No Small Scale Tests Proposed	Design Dependent
Bore Effect / Finnegan Effect	Burn-to-Violent-Reaction (BVR) Subscale Component Testing High Velocity Shotgun Test High Strain Rate Mechanical Properties Testing Pick-up Test (Reaction Acceleration)	Shock Hugoniots of Energetic Materials and Impactor Damage Dependency Design Dependent Impactor Shape Dependent
Reflected Shock Possible	Plate Impact Test	Design Dependent
XDT	Shock Test of Damaged Material Double-shock Gap Test High Strain Rate Mechanical Properties Testing High Strain Rate Fracture Mechanics Testing	High Strain Rate Mechanical Properties High Strain Rate Fracture Mechanics

KEY FACTORS/ REACTION MECHANISMS	TOOLS FOR ANALYSIS	PROPERTIES REQUIRED
Ignition	Differential Scanning Calorimetry (DSC) or other Test to Measure Temperature of Ignition Hot Ball Test / Hot Fragment Conductive Ignition Test Friction Sensitivity Test Mechanical Properties Testing at Relevant Strain Rates Fracture Mechanics Testing at Relevant Strain Rates	High Strain Rate Mechanical Properties High Strain Rate Fracture Mechanics Kinetics and Thermochemistry of EM Decomposition as a Function of Temperature and Pressure
Significant Material Damage	Friability (Shotgun Test) Tube Test Hopkinson Bar Mechanical Properties Testing at Relevant Strain Rates Fracture Mechanics Testing (Fracture Toughness)	Material Properties Toughness at Appropriate Strain Rates (Fracture Mechanics Properties) Additional Surface Area Generation
Sufficient Venting	Mechanical Properties Testing Burn Rate (at High Pressure) Projectile properties (Velocity, Geometry, Mass, Orientation) Close Bomb Test Ballistic Limit Testing	Highly Dependent on Munition Design High Strain Rate Mechanical Properties Effect of Confinement
Layered Burning (normal surface regression)	Burn Rate (Strand Burner) Closed Bomb Burning Tube Tests Small Scale Motor Tests	Burn Rate as a Function of Temperature and Pressure
Propulsion	No Small Scale Tests Proposed	Dependent on Munition Design

TABLE D-2 .Examples of tests that can be used to generate the data required in Table D-1

DATA REQUIRED	PROPERTIES	TEST TO BE CARRIED OUT	GENERAL POINTS
Kinetics and thermo chemistry of EM physical changes or decomposition	• Porosity	• Density Measurements	• Over a suitable temperature, pressure, dimensions and geometries range including ones resulting from mechanical or/and thermal damages
	• Pore size	• Refractive Matching Fluid • Atomic Force Microscopy • Scanning Electron Microscopy (SEM)	
	• Particle size	• Microsonic Techniques	
	• Crystal quality	• SEM • Microscopical Techniques • X-ray Diffraction • Density measurement test	
	• Chemical reaction rate	• Adiabatic bomb calorimeter • Thermo analytical techniques <ul style="list-style-type: none"> • Differential Scanning Calorimetry (DSC) • Dynamic Mechanical Thermal Analysis • Thermo Mechanical Analysis (TMA) • Thermo Gravimetric Analysis (TGA) • Differential Thermal Analysis (DTA) • Dilatometry 	
Burning rate	• Burn rate (Undamaged and damaged material)	• Strand burner • Closed bomb • Hybrid combustion bomb	<ul style="list-style-type: none"> • Over a suitable temperature, pressure dimensions and geometries range including ones resulting from mechanical or/and thermal damages • Not measured routinely • Highly dependent on damage characteristics • Fractures • Porosity • Dewetting
	• Friability: • Propensity to fracture/damage	• Shotgun test (Friability test) • Bullet damage test • Hopkinson bar • Failure modulus test • Taylor impact test • Fracture toughness	
	• Damage Characterisation	• Sectioning microscopy • X-Ray tomography • Closed bomb (Surface area) • Neutron and X-Ray diffraction • Coefficient of Thermal Expansion	

DATA REQUIRED	PROPERTIES	TEST TO BE CARRIED OUT	GENERAL POINTS
Mechanical physical and thermal properties of munitions individual inert components		<ul style="list-style-type: none"> • Thermal expansion measurements • Thermo analytical techniques <ul style="list-style-type: none"> • Differential Scanning Calorimetry (DSC) • Dynamic Mechanical Thermal Analysis (DTMA) • Thermo Mechanical Analysis (TMA) • Thermo Gravimetric Analysis (TGA) • Differential Thermal Analysis (DTA) • Dilatometry • Mechanical properties analysis <ul style="list-style-type: none"> • Uniaxial Tensile/Compressive Testing (Low Strain Rates) • Servohydraulic Mechanical Test (at rates from 1 to 500/s) • Hopkinson Bar (at Rates from 100 to 10⁴/s) 	<ul style="list-style-type: none"> • Over a suitable temperature, pressure, dimensions and geometries range including ones resulting from mechanical or/and thermal damages
Thermal physical and mechanical properties of munitions EM		<ul style="list-style-type: none"> • Same as in Mechanical physical and thermal properties of munitions individual inert components • AOP-7 test category 102-02-xxx 	<ul style="list-style-type: none"> • Over a suitable temperature, pressure dimensions and geometries range including ones resulting from mechanical or/and thermal damages
Mechanical physical and thermal properties of munitions assembly and packaging		<ul style="list-style-type: none"> • Same as in Mechanical physical and thermal properties of munitions individual inert components • Components bond strength <ul style="list-style-type: none"> • AOP-7 Series 102.01 tests • Compatibility test in an environment representative of IM tests 	<ul style="list-style-type: none"> • Over a suitable temperature, pressure dimensions and geometries range including ones resulting from mechanical or/and thermal damages
Detailed munitions design		<ul style="list-style-type: none"> • Technical Data Package • X-Ray • Munitions disassembly 	<ul style="list-style-type: none"> • Geometry and physical size • Loading density • External confinement • Gas tightness • Free volume • Casing type

ASSESSMENT OF SYMPATHETIC REACTION

Overview

1. The primary purpose of the Sympathetic Reaction (SR) protocols is to expose the underlying chemistry and physics, to identify important controlling parameters and phenomena, and to expose important data gaps. They may also provide helpful guidance to people who are trying to solve particular problems relating to energetic material response. However, they are not tools which can be used to predict results or to replace experiment. There are a number of questions, gaps in data, and gaps in understanding which preclude a fully predictive capability.

2. The SR protocols are based on the idea that a munition will face a hierarchy of hazards when an adjacent donor(s) undergoes an explosive reaction – usually detonation. The initial hazard, the shock generated during impact of fragments or blast on the munition, may lead to a prompt (and severe) response if shock criteria are satisfied. If not, then the munition may undergo a delayed response caused by interactions between the munition case and the energetic material. The protocols lead the user through this series of potential hazards and probable outcomes.

3. In order to simplify the task of developing a protocol for SR, the problem has been broken down into three categories:

- Single donor and single acceptor
- Single donor and multiple acceptor
- Multiple donor and multiple acceptor

4. The single donor and acceptor, or one-on-one scenario is the simplest to analyze. It has been further divided into two cases depending on the presence of a buffer between the donor and acceptor, since such a buffer can significantly affect the physics of the event.

5. In the single donor and multiple acceptor, or one-on-many situation, the single donor may be surrounded by multiple acceptor rounds and, possibly, some other confinement. The effects of this configuration can vary greatly from that of the one-on-one case.

6. Finally, the SR protocols treat the scenario of multiple donors and multiple acceptors, or stack-on-stack. This situation deals with the potential to propagate the detonation of one group of munitions to a second group. It takes into account the issues from the simpler scenarios, adds new issues, and, where necessary, refers the user back to the one-on-many protocol.

7. Table E-1 identifies tests and tools that are pertinent to each of the decision points in the protocols and the materials properties required to assist in the modelling or prediction of the results of such tests. Table E-2 gives examples of tests that can be used to determine values for the properties identified in Table E-1. These tables are neither exhaustive nor exclusive, and users of the protocols should seek to use the most up to date and well validated tools available to them.

The Simplified Sympathetic Reaction Hazard Protocol

8. The simplified protocol in Figure E-1, presents the hazard assessment protocol logic in a form that captures the overall response mechanisms. It combines the individual steps assuming that, given certain conditions, the overall mechanism will determine the response.
9. When applying the simplified protocol, the following should be considered:
- a. The decision process does not allow for responses other than those caused by shock to detonation transition (SDT). In cases where XDT or DDT is a significant possibility (most notably TNT based explosives and detonable propellants), this possibility must be considered if it is shown that SDT does not occur first. At present, XDT and DDT cannot be predicted to occur, although they are known to be much less likely with solid plastic bonded explosive (PBX) charges than with other materials.
 - b. Where adjacent munitions are struck by the expanding donor case (with or without attenuating effects of buffers or packaging), the results can be predicted using hydrocodes with a suitable EM reactivity model.
 - c. Arena test results may be used to generate the fragmentation effects from the donor.
 - d. No account is made for the possibility of acceptor munitions reacting as a result of secondary impacts (impacts on the ground or surrounding structure after being propelled by the donor reaction). Such reactions may be very significant but are very dependant on surroundings and are not called up in the present test methods.

The Detailed Sympathetic Reaction Hazard Protocols

10. The primary purpose of the detailed sympathetic reaction protocols is to expose the underlying chemistry and physics, to identify important controlling parameters and phenomena, and to expose important data gaps. They may also provide helpful guidance to when trying to solve particular problems relating to energetic material response. However, they are not tools which can be used to predict results or to replace experiment; there are a number of questions, gaps in data, and gaps in understanding which preclude achieving a fully predictive capability.

11. The detailed protocols in Figures E-2 to E-5 consider each step in the sequence of events leading to some response, and examine the details of each mechanism. Because sympathetic reaction can occur in several configurations involving both single and multiple donors and acceptors, the problem has been broken down into three categories.

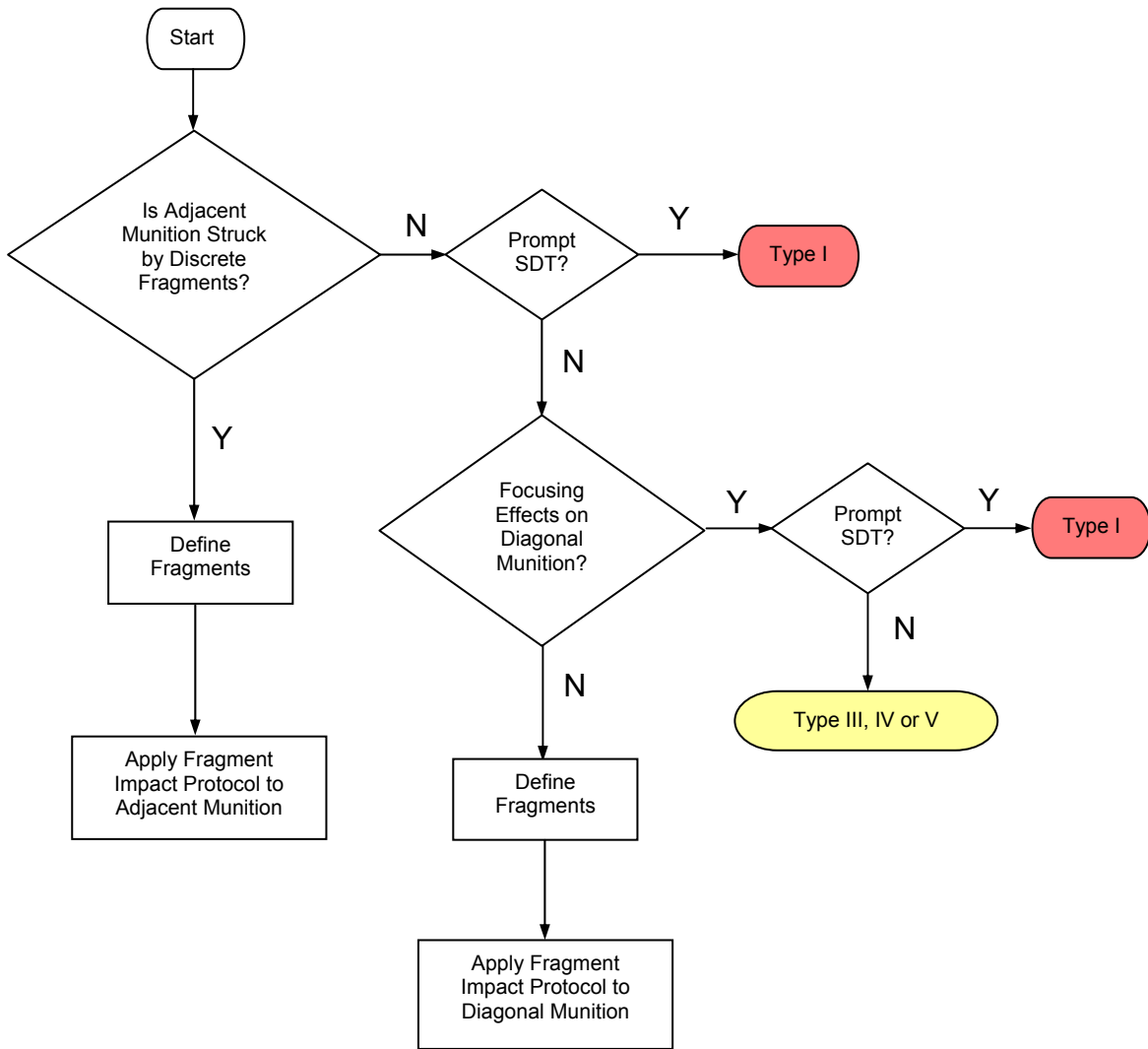

Figure E-1 Simplified Hazard Protocol – Sympathetic Reaction

General Breakdown of the problem

12. To simplify the task, the sympathetic detonation problem was broken into three categories, as shown in Figure E-2 and described below:

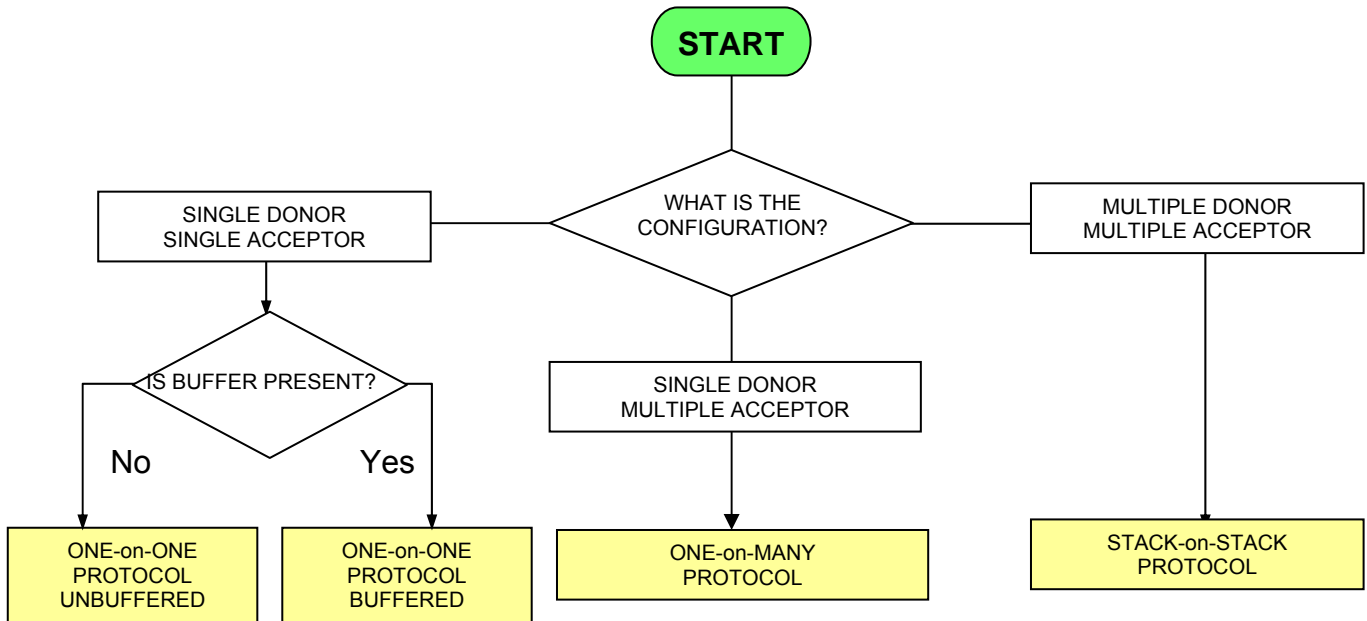

Figure E-2- General Breakdown of the Problem

12.1 **Single donor and single acceptor (one-on-one) tests.** This is the easiest case to analyze. It has been further subdivided into cases with and without a buffer between donor and the acceptor. The presence of a buffer can significantly alter some of the physics involved.

12.2 **Single donor and multiple acceptor (one-on-many) tests, with or without confinement.** In this category there is only one donor round, but the donor may be surrounded by multiple acceptor rounds and perhaps by other confinement, such as the wall of an ammunition compartment. The presence of multiple rounds and confinement can significantly alter the physics from what is seen in one-on-one tests.

12.3 **Multiple donor and multiple acceptor (stack-on-stack) tests.** In this category, a group of rounds are detonated, and the object is to prevent propagation to a second group. The issues involved become more complicated as one proceeds from category 1 to 3: the higher categories involve all of the issues in the preceding categories, plus others. Thus, the protocols for the higher categories refer back to the protocols for the lower categories.

Single Donor And Single Acceptor Tests

13. The protocol for the unbuffered one-on-one case is shown in Figure E-3. It deals with one-on-one tests where there is nothing, except air, between the donor and the acceptor. The physics of the process can change as the distance between the rounds changes. Thus, the protocol separates into three branches as follows:

13.1 **Widely spaced rounds (separation distance greater than about 2 round diameters).** In this case, the fragments from the donor act individually on the acceptor and the situation is relatively simple (at least from the point of view of writing a protocol). Generally, the problem reduces to one of fragment impact, a problem which is treated by a separate protocol. In rare cases, air blast may be a mechanism, but air blast is an inefficient initiation source and can generally be neglected with widely spaced rounds. Sensitive explosives which are either unconfined or lightly confined with low density (less than explosive density) material may be an exception, but this has not been included in the protocol chart.

13.2 **Closely spaced rounds (separation less than about one-half of a round diameter).** In this situation, the expanding case from the donor either hits the acceptor before it fragments, or it hits the acceptor in the form of closely spaced fragments which act as a curved plate. Broadly speaking, two types of initiation processes may occur:

- a. Shock initiation. The most obvious and likely mechanism in this situation is shock initiation due to the impact of the flyer plate. The velocity of the expanding case and the shock pressure in the acceptor can be calculated relatively easily. For very close spacings, they increase with distance. Thus, there can be two critical separation distances, a lower limit below which propagation does not occur and an upper limit above which it does not occur (because the plate has separated into discrete fragments.) The response of the acceptor can be estimated using P^2t relations or computed more accurately using various shock initiation models.
- b. "Non-shock" mechanisms. The term "non-shock mechanisms" refers to a variety of processes resembling DDT or XDT which may cause initiation in some manner other than a simple shock to detonation transition. In the unbuffered, one-on-one situation they may be much less likely than they are in other situations, but they cannot be ignored. In the protocol, the non-shock mechanisms have been sub-divided as shown below:
 - i. Initiation on recompression. There are well documented accounts of energetic materials initiating on recompression and the process is often referred to as "XDT". Apparently, the initial shock damages the material, and perhaps ignites it, without driving it to detonation. A following compression initiates detonation reflected from the back of the round or it could be the acceptor round hitting some other object. Unfortunately, models of this process are still rudimentary at best, and this area constitutes one of the knowledge gaps.
 - ii. Deflagration to detonation transition (DDT). DDT is not usually observed in secondary explosives with normal amounts (less than 3%) of porosity. However, in sympathetic detonation tests, there can be extensive damage to the acceptor charge, and there is a possibility that this could lead to DDT if the explosive is ignited on a multiplicity of fracture surfaces and if the confinement remains intact. Although DDT in porous media has been studied for many years, the events that are postulated here could be quite different (because the porosity is generally much less), and this must be considered another knowledge gap.
 - iii. Secondary impacts. If the acceptor round is not immediately detonated, it may be thrown against some nearby object and detonate as a result of the second impact (much like an XDT event). This is a more likely mechanism in stack-on-stack tests, but it is included here because the stack-on-stack and one-on-many protocols branch back to this protocol.
 - iv. Blast. For cased rounds, in this close-in situation, the blast wave is not separate from the impact of the casing. Consequently, it is not shown as a separate box in

the protocol chart. Nevertheless, the explosive products can have a significant influence on the pressure time history in the acceptor round, and can affect all of the possible mechanisms listed above. When the explosive is cased in a low density material, such as a plastic, the explosive products can dominate the process.

13.3 **The intermediate case where the fragments are discrete, but where the impacts may be close enough that they act synergistically.** In this regime, the fragments are typically long strips which are quite close together. Gas products are escaping between the strips, so a blast wave (explosive products) may be in front of the fragments and may have sufficient strength to influence the test results. The blast wave could pre-compress and pre-accelerate the acceptor so that it is less sensitive to the impact of the fragments, or it could damage the acceptor and make it more sensitive to the fragments. (The double compression associated with the impact of the blast wave and then the fragments could act like the double compression in an XDT experiment.) This effect might be especially significant if the acceptor has a large internal void (as in a rocket motor), which permits extensive cracking. A further complication in this regime is that the fragments may be close enough for the shocks from adjacent impacts to collide and amplify. After evaluating the effects of the blast wave and multiple fragments, the protocol chart branches to the Bullet/Fragment Impact Protocol. However, it should be noted that all of the phenomena considered for closely spaced rounds can still be active here (and are considered in the Bullet/fragment Impact Protocol).

One-On-One Tests With A Buffer

14. The presence of a buffer between donor and acceptor can significantly alter the physics of an experiment, and even thin buffers can often suppress sympathetic detonation. The protocol chart (Figure E-4) first asks if the buffer is reactive. Reactive buffers (usually propellant charges) have been used successfully to suppress sympathetic detonation. However, reactive buffers are not always effective, and the WAG 11 group felt that there was too little information to try to create a protocol for them. After dealing with the reactive buffer question, the protocol divides into three branches which deal with different buffer configurations. The division is somewhat artificial and intermediate cases exist, but each of the specified configurations involves unique problems. A description of each configuration and its special problems follows.

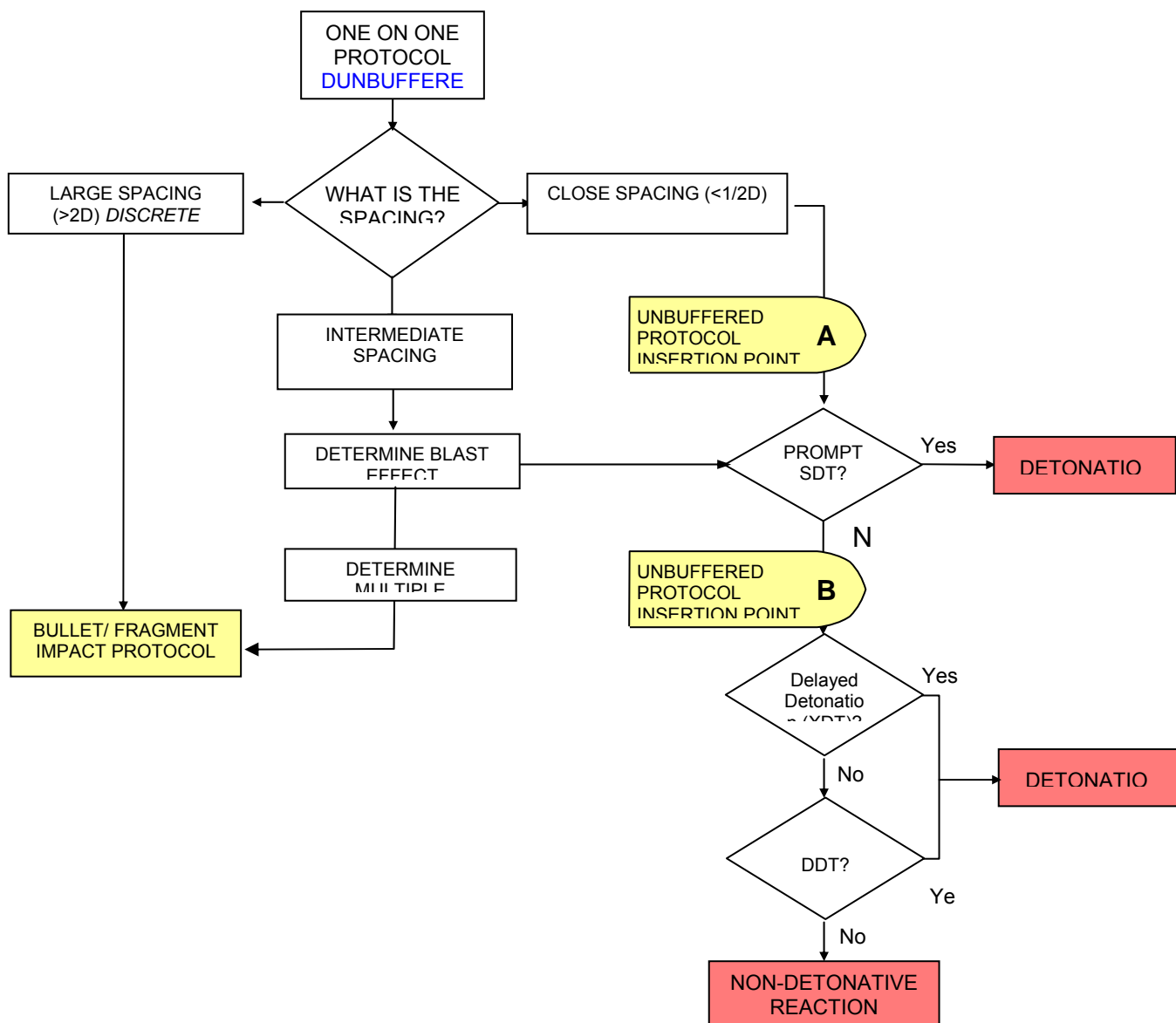

Figure E-3 One on One Protocol (Unbuffered)

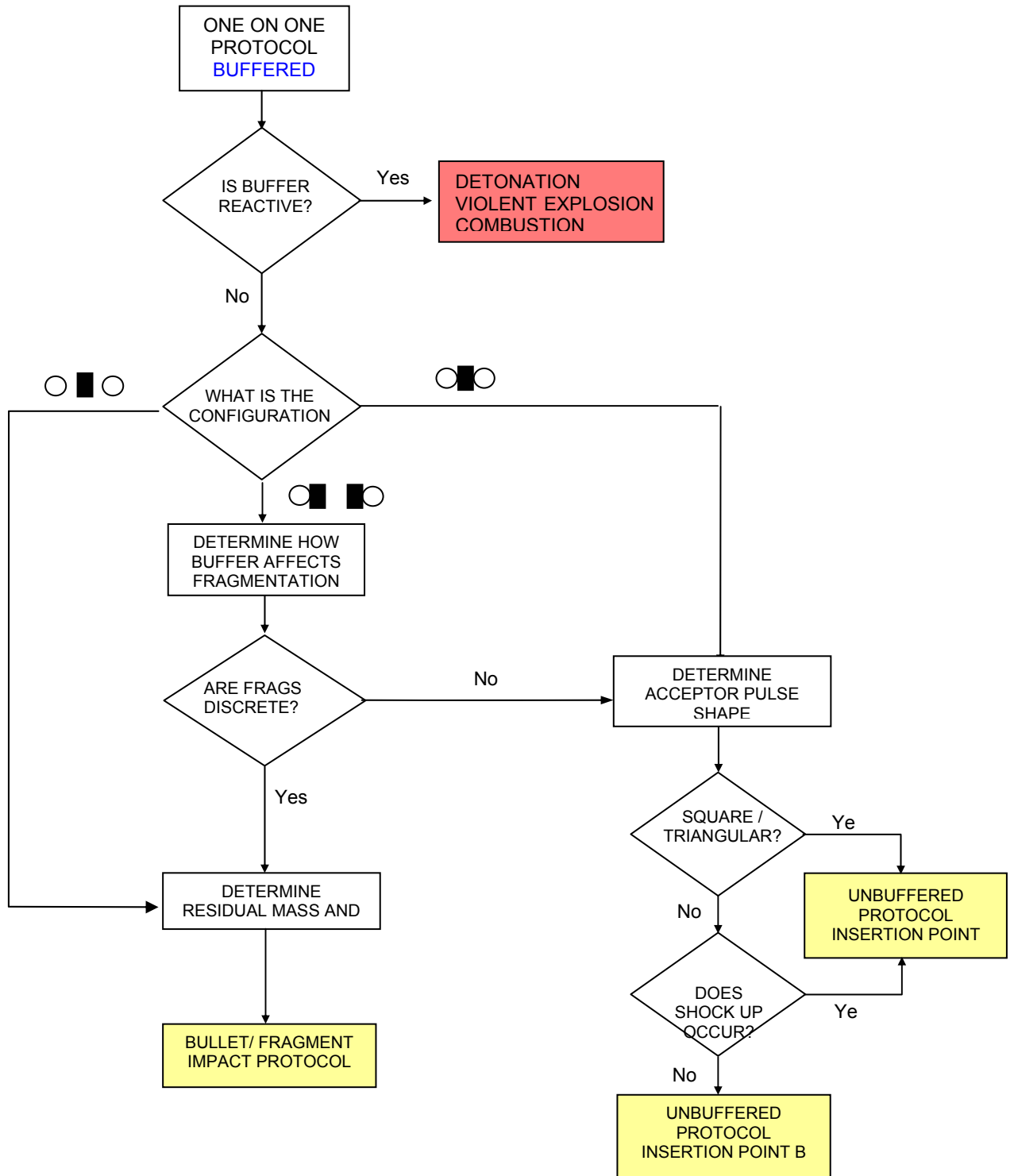

Figure E-4. One-On-One Protocol (Buffered)

14.1 **Configurations where the buffer fills the space between donor and acceptor.** Quite small buffers can often suppress sympathetic detonation in this case. Buffers work best when they fill the space between the rounds, because in this configuration, they keep the casing from achieving its maximum velocity. Such buffers profoundly alter the pressure time profile at the acceptor, The buffer significantly reduces the peak pressure seen by the acceptor round and also spreads the pressure pulse out so that the acceptor sees a ramped compression wave rather than a true shock. Both effects have a strong effect on shock initiation.

14.2 The effect of reduced pressure is easily treated by existing empirical rules and models, but the effect of rise time (ramp wave initiation) is more difficult to deal with. The degree of ramping (rise time) affects the formation of hotspots. Unfortunately, the experimental data base on rise time effects is sparse, and there are no empirical rules which can be used to predict the effect of rise time. Furthermore, the existing hot spot models must make many simplifying assumptions, so while they may be useful in a qualitative sense, they can not be used for quantitative predictions. Consequently, existing shock initiation models are inadequate to model ramp wave behaviour. Rise times as low as 1 microsecond will probably suppress shock initiation in most cases, but this will depend on the mean pore size in the explosive and other parameters. An additional complication is that ramp waves “shockup” as they propagate into the explosive, so the rise time at the back surface of the acceptor will not be the same as at the input surface. Thus a small rise time may serve only to delay, rather than prevent, initiation.

14.3 The protocol deals with these issues by first asking that the pulse shape be determined. Then it asks if the wave is sufficiently ramped to suppress hotspot formation. Unfortunately, this is a question which cannot be answered at present by any method other than experiment (and even then interpretation of the results may be difficult). If the answer is yes, the protocol assumes that the compression wave is equivalent to a shock and branches to the protocol for closely spaced unbuffered rounds (point A). If the answer is no, the protocol asks whether the pulse “shocks up” while it is still in the explosive, If the answer is yes, it is assumed that the pulse acts like a shock, and the protocol branches to the unbuffered protocol at point A. If the answer is no, it is assumed that shock initiation will not occur, but all of the other mechanisms which are considered by the unbuffered protocol are still possible, so the protocol branches to the unbuffered protocol at point B. Since buffers mitigate shock initiation, the “non-shock” mechanisms discussed above are probably more important in the buffered case than in the unbuffered case.

14.4 **A single buffer which is separated from both donor and acceptor by large air gaps.** In this case the fragments from the donor round form normally. The buffer reduces their mass and velocity, and it may deflect some so that they don't hit the acceptor; but the situation may be treated using the Bullet/Fragment Impact Protocol.

14.5 **There is a buffer in contact with both donor and acceptor, but there is an air gap in between.** In this case, the presence of the buffer may affect the fragmentation of the donor round. The size and velocity of the fragments may be different (they are likely to be bigger and slower) than they would be without a buffer. When the modified fragments hit the acceptor, the buffer there will attenuate the impact shock and reduce the possibility of shock initiation. This phenomenon is treated in the One on One (unbuffered) protocol, so the SD Protocol branches to the One on One (unbuffered) protocol at this point.

Single Donor/Multiple Acceptor Tests, With Or Without Confinement

15. This category includes the case where one round in a large stack detonates or where one round in an ammunition compartment detonates. All of the considerations discussed in the previous category apply, but other considerations are necessary. The fact that a certain round, with or without a buffer, passes a one-on-one sympathetic detonation test does not mean that it will not sympathetically detonate in a stack or in the confinement of a compartment. Some specific examples of this are discussed below. The One on Many protocol (Figure E-5) starts by evaluating the one-on-one situation, and then addresses the additional factors which are described below:

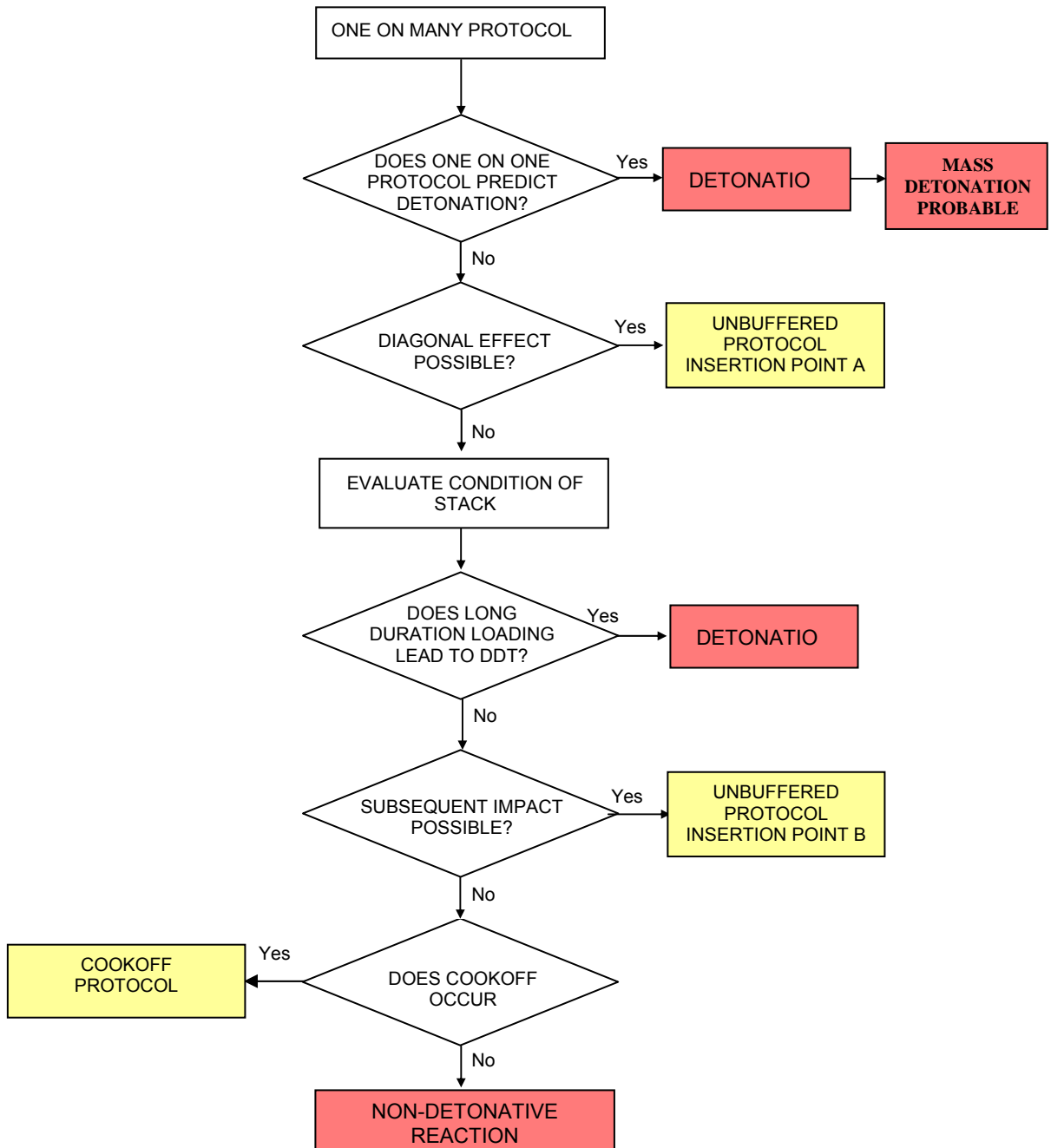

Figure E-5 One on Many Protocol

15.1 **Fragment focusing effects.** Fragment focusing must be considered when one tries to move from one-on-one tests to larger arrays.

15.2 **Subsequent impacts.** In these types of experiments, there are many opportunities for initiation by recompression (XDT). A round may be damaged by the impulse from the donor and then recompressed when it slams into an adjacent round or the wall of a compartment. Alternatively, a round may be damaged by the impulse from the donor, and recompressed when another acceptor round reacts in a low order (non-detonative) fashion. The multiply shocked round might then detonate.

15.3 **Long duration loading (the effect of compartment confinement and venting).** Ammunition compartment tests have shown that the strength of the compartment, the size and location of the vents, and the presence of gun propellant can affect the propagation of detonation between warheads. Furthermore, the failures that occurred in compartment testing frequently involved reactions which were delayed by times of several hundreds of microseconds or even several milliseconds. These times are much too long for shock initiation.

15.4 Detailed understanding of these types of events is almost totally lacking. The multiple stimuli effects mentioned above may be involved. If the rounds closest to the donor in a stack do not detonate immediately, they will nevertheless be crushed, damaged, and perhaps broken open. The crushed and damaged material may burn, and the rate at which it burns is determined by the pressure level and by the extent of the damage induced surface area. Confinement in a compartment will keep the pressure high and will increase the burn rate. The presence of propellant, even if the propellant doesn't detonate itself, will do the same thing. Thus all of these factors may facilitate a deflagration to detonation transition. It will be very difficult to develop criteria for the occurrence of this type of event, and there is certainly a data gap in this area.

15.5 **Cook-off.** If the rounds do not detonate immediately, they may be exposed to a fire. If a round detonates as a result of cook-off, sympathetic detonation may now be possible because the stack has been significantly altered as a result of earlier events.

15.6 **Mass reaction versus propagation to a few acceptors.** If sympathetic detonation occurs promptly in the nearest neighbours, there is little doubt that it will propagate throughout the stack. In other cases, one must evaluate whether the circumstances causing sympathetic detonation are peculiar to a few rounds in the stack and whether further propagation will occur (in the chart, the protocol branches back to the beginning to indicate this evaluation).

Multiple Donor/Multiple Acceptor Tests

16. This category involves tests where a whole stack of donors detonates, and the objective is to see if an adjacent stack will detonate. Once again all of the considerations given above apply, but some additional considerations are necessary. The protocol goes through the additional considerations, which are described below, and then branches back to the one-on-many protocol.

16.1 **Alternation of fragment sizes, velocities and spatial distribution.** When a whole stack detonates, the velocity, size, and spatial distribution of the fragments may be altered significantly from what they would be for a single munition. When two adjacent warheads detonate, an interaction zone forms between them which produces a concentrated jet of fragments at velocities which greatly exceed the velocity of the fragments from a single warhead. The number of fragments is also enhanced in these directions. When an array of donor munitions is initiated by "natural communication" (one round is initiated and the rest initiate sympathetically), the mode of fragmentation is altered, as compared with the detonation of a single munition, and very large fragments are formed and projected in certain directions. The fragment spray from the interaction areas probably presents the worst case for sympathetic detonation, but the larger fragments could be important in some situations.

16.2 **The impact of the buffer, if any, on the acceptors.** If a buffer is used in this type of test, it may be propelled at considerable velocity into the acceptors and may cause initiation of the acceptors by shock initiation or by massive crushing

16.3 **Effect of long duration stimuli.** This effect has already been discussed as part of the one-on-many protocol, but it can be particularly significant in these large scale tests.

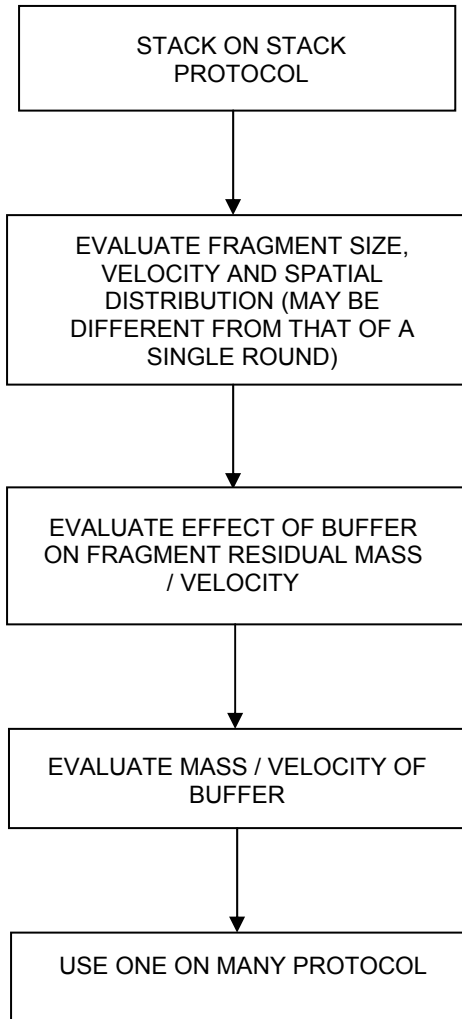

Figure E-6 Stack on Stack Protocol

TABLE E-1 Examples of tools available and data required to analyse sympathetic reaction paths

KEY FACTORS/ REACTION MECHANISMS	TOOLS FOR ANALYSIS	PROPERTIES REQUIRED
Shock to Detonation Transition (SDT)	Gap Test Wedge Test Critical Diameter Test Plate Impact Test High Velocity Shotgun Test	Scaling Effects Fragment Characteristics Shock Hugoniot of Energetic Materials and Impactor Shock Pressure and Duration Pop Plot Critical Energy Design Dependent
Penetrate Case / Severe Distortion	Mechanical Properties of Case and Projectile at High Strain Rate Projectile Physical Characteristics (Velocity, Geometry, Mass)	Mechanical Properties of Case and Projectile Geometry and Ballistics of Projectile Ballistic Limit for Case Projectile Break-up and Resulting Fragment Characteristics Design Dependent
Hit Bare EM	No Small Scale Tests Proposed	Design Dependent
Reflected Shock Possible	Plate Impact Test	Design Dependent
XDT	Shock Test of Damaged Material Double-shock Gap Test High Strain Rate Mechanical Properties Testing High Strain Rate Fracture Mechanics Testing	High Strain Rate Mechanical Properties High Strain Rate Fracture Mechanics

KEY FACTORS/ REACTION MECHANISMS	TOOLS FOR ANALYSIS	PROPERTIES REQUIRED
Ignition	Differential Scanning Calorimetry (DSC) or other Test to Measure Temperature of Ignition Hot Ball Test / Hot Fragment Conductive Ignition Test Friction Sensitivity Test Mechanical Properties Testing at Relevant Strain Rates Fracture Mechanics Testing at Relevant Strain Rates	High Strain Rate Mechanical Properties High Strain Rate Fracture Mechanics Kinetics and Thermochemistry of EM Decomposition as a Function of Temperature and Pressure
Significant Material Damage	Friability (Shotgun Test) Tube Test Hopkinson Bar Mechanical Properties Testing at Relevant Strain Rates Fracture Mechanics Testing (Fracture Toughness)	Material Properties Toughness at Appropriate Strain Rates (Fracture Mechanics Properties) Additional Surface Area Generation
Sufficient Venting	Mechanical Properties Testing Burn Rate (at High Pressure) Projectile properties (Velocity, Geometry, Mass, Orientation) Close Bomb Test Ballistic Limit Testing	Highly Dependent on Munition Design High Strain Rate Mechanical Properties Effect of Confinement
Layered Burning (normal surface regression)	Burn Rate (Strand Burner) Closed Bomb Burning Tube Tests Small Scale Motor Tests	Burn Rate as a Function of Temperature and Pressure
Propulsion	No Small Scale Tests Proposed	Dependent on Munition Design

TABLE E-2 .Examples of tests that can be used to generate the data required in Table E-1

DATA REQUIRED	PROPERTIES	TEST TO BE CARRIED OUT	GENERAL POINTS
Kinetics and thermo chemistry of EM physical changes or decomposition	<ul style="list-style-type: none"> • Porosity 	<ul style="list-style-type: none"> • Density Measurements 	<ul style="list-style-type: none"> • Over a suitable temperature, pressure, dimensions and geometries range including ones resulting from mechanical or/and thermal damages
	<ul style="list-style-type: none"> • Pore size 	<ul style="list-style-type: none"> • Refractive Matching Fluid • Atomic Force Microscopy • Scanning Electron Microscopy (SEM) 	
	<ul style="list-style-type: none"> • Particle size 	<ul style="list-style-type: none"> • Microsonic Techniques 	
	<ul style="list-style-type: none"> • Crystal quality 	<ul style="list-style-type: none"> • SEM • Microscopical Techniques • X-ray Diffraction • Density measurement test 	
	<ul style="list-style-type: none"> • Chemical reaction rate 	<ul style="list-style-type: none"> • Adiabatic bomb calorimeter • Thermo analytical techniques <ul style="list-style-type: none"> • Differential Scanning Calorimetry (DSC) • Dynamic Mechanical Thermal Analysis • Thermo Mechanical Analysis (TMA) • Thermo Gravimetric Analysis (TGA) • Differential Thermal Analysis (DTA) • Dilatometry 	
Burning rate	<ul style="list-style-type: none"> • Burn rate (Undamaged and damaged material) 	<ul style="list-style-type: none"> • Strand burner • Closed bomb • Hybrid combustion bomb 	<ul style="list-style-type: none"> • Over a suitable temperature, pressure dimensions and geometries range including ones resulting from mechanical or/and thermal damages • Not measured routinely • Highly dependent on damage characteristics • Fractures • Porosity • Dewetting
	<ul style="list-style-type: none"> • Friability: • Propensity to fracture/damage 	<ul style="list-style-type: none"> • Shotgun test (Friability test) • Bullet damage test • Hopkinson bar • Failure modulus test • Taylor impact test • Fracture toughness 	
	<ul style="list-style-type: none"> • Damage Characterisation 	<ul style="list-style-type: none"> • Sectioning microscopy • X-Ray tomography • Closed bomb (Surface area) 	

DATA REQUIRED	PROPERTIES	TEST TO BE CARRIED OUT	GENERAL POINTS
		<ul style="list-style-type: none">• Neutron and X-Ray diffraction• Coefficient of Thermal Expansion	

DATA REQUIRED	PROPERTIES	TEST TO BE CARRIED OUT	GENERAL POINTS
Mechanical physical and thermal properties of munitions individual inert components		<ul style="list-style-type: none"> • Thermal expansion measurements • Thermo analytical techniques <ul style="list-style-type: none"> • Differential Scanning Calorimetry (DSC) • Dynamic Mechanical Thermal Analysis (DTMA) • Thermo Mechanical Analysis (TMA) • Thermo Gravimetric Analysis (TGA) • Differential Thermal Analysis (DTA) • Dilatometry • Mechanical properties analysis <ul style="list-style-type: none"> • Uniaxial Tensile/Compressive Testing (Low Strain Rates) • Servohydraulic Mechanical Test (at rates from 1 to 500/s) • Hopkinson Bar (at Rates from 100 to 10⁴/s) 	<ul style="list-style-type: none"> • Over a suitable temperature, pressure, dimensions and geometries range including ones resulting from mechanical or/and thermal damages
Thermal physical and mechanical properties of munitions EM		<ul style="list-style-type: none"> • Same as in Mechanical physical and thermal properties of munitions individual inert components • AOP-7 test category 102-02-xxx 	<ul style="list-style-type: none"> • Over a suitable temperature, pressure dimensions and geometries range including ones resulting from mechanical or/and thermal damages
Mechanical physical and thermal properties of munitions assembly and packaging		<ul style="list-style-type: none"> • Same as in Mechanical physical and thermal properties of munitions individual inert components • Components bond strength <ul style="list-style-type: none"> • AOP-7 Series 102.01 tests • Compatibility test in an environment representative of IM tests 	<ul style="list-style-type: none"> • Over a suitable temperature, pressure dimensions and geometries range including ones resulting from mechanical or/and thermal damages
Detailed munitions design		<ul style="list-style-type: none"> • Technical Data Package • X-Ray • Munitions disassembly 	<ul style="list-style-type: none"> • Geometry and physical size • Loading density • External confinement • Gas tightness • Free volume

			• Casing type
--	--	--	---------------

ASSESSMENT OF SHAPED CHARGE JET IMPACT

Overview

1. Reaction of a munition to the shaped charge jet impact stimulus occurs because there is either direct shock initiation (SDT), bow shock initiation (BSDT) or ignition of damaged energetic material as the jet passes through the energetic material. While a very wide range of shaped charge jet impact scenarios are possible in hazard situations, for the purposes of IM these are simplified to two generic categories, broadly representative of Rocket Propelled Grenades and top attack bomblets.
2. The principal factors affecting the response to such a stimulus are its shock sensitivity under confined conditions, the degree of confinement of the energetic material, the level of energetic material damage and the propensity for the energetic material to undergo Deflagration to Detonation Transition (DDT).
3. Table F-1 identifies tests and tools that are pertinent to each of the decision points in the protocols and the materials properties required to assist in the modelling or prediction of the results of such tests. Table F-2 gives examples of tests that can be used to determine values for the properties identified in Table F-1. These tables are neither exhaustive nor exclusive, and users of the protocols should seek to use the most up to date and well validated tools available to them.

The Shaped Charge Jet Impact Hazard Protocol

4. It has not proved possible to generate a simplified protocol for the assessment of Shaped Charge Jet Impact hazard. The complexity of the problem, coupled with the level of detailed mechanistic understanding that exists, has led to the development of a detailed protocol that is broken down into five parts for ease of use.
5. The protocols presented here are based on the original TTCP protocol, with modifications proposed by the group of experts at the NIMIC workshop on Shaped Charge Jet Impingement (1996).
6. These protocols, Figures F-1 to F-5, present the hazard assessment protocol logic in a form that captures the detailed response mechanisms.

Notes on the SCJ protocols

7. The general principles the reaction mechanisms are generally understood. The dynamic interaction of a hypervelocity jet and a bare, lightly covered or heavily covered HE can result in two types of shocks:
 - a. **The Impact shock.** This is the non-steady shock produced by the initial impact of the jet on a surface and transmitted to the HE either directly (if bare) or through a thin cover plate.

Pressures at this initial point of contact can be in excess of one megabar. Initiation occurs immediately after impact within a few millimetres of the explosive surface or does not occur by this mechanism. The shock pressure is quickly weakened by rarefactions entering from the boundaries at local sound velocities. The related reaction mechanism is the Shock to Detonation Transition (SDT).
 - b. **The Bow shock.** This is the steady shock appearing only when the jet penetrates a material, in this case an explosive, at supersonic speeds. Its velocity is equal to the penetration rate.

The bow wave forms a shock front followed by a ramp wave towards the theoretical Bernoulli pressure at the interface with the jet tip. If the cover is more than a few jet diameters thick, the impact shock is attenuated before it reaches the explosive and the bow wave from the jet penetrating the explosive becomes the dominating mechanism for initiation.

Under certain conditions and a certain distance (the distance for the bow shock to set-up in the explosive and the explosive to be initiated), this shock can initiate the explosive. For bow waves below the critical condition, the explosive does not detonate. The jet penetrates through the explosive with the bow wave causing disruption and/or reaction. The related reaction mechanism is the Bow Shock to Detonation Transition (BSDT).

8. In the original TTCP WAG-11 protocol only continuous jets and first impact fragments from particulated jets were taken into account:

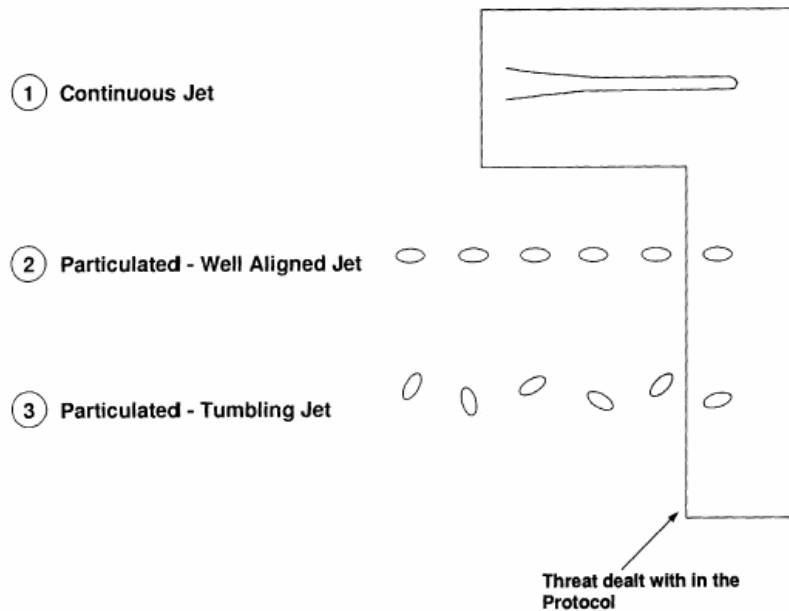

Figure F-1: Threats dealt with in the WAG-11 protocol

9. The principle modifications to the original WAG-11 protocols are as follows:
- a. Adding a protocol taking into account multiple impacts. This protocol is referred to as the Shaped Charge Jet Multiple Impact Protocol (now Part 5 of the SCJ Impact Protocol).
 - b. Mixing and modifying the Bare/Thinly Covered Solid EM Branch (formerly Part 2) and the Thickly Covered Solid EM Branch (formerly Part 3) of the original WAG-11 SCJ Impact Hazard Protocol. This was done by considering the overall reaction mechanisms rather than the detailed criteria for each mechanism (new Part 2 of the SCJ Impact Protocol).
 - c. By doing so, the uncertainty concerning:
 - The ratio critical diameter / sample diameter (d_c/d_s)
 - The ratio critical diameter / jet diameter (d_c/d_j)
 - The V^2d or u^2d configuration dependant values is removed, and the necessity to perform lots of tests to determine the V^2d values for the various configurations disappears.
 - d. **Adding a liquid energetic materials branch in the entrance** (Figure F-2, Part 4 of the SCJ Impact Hazard Protocol). No specific protocol is proposed due to the lack of knowledge in this field.

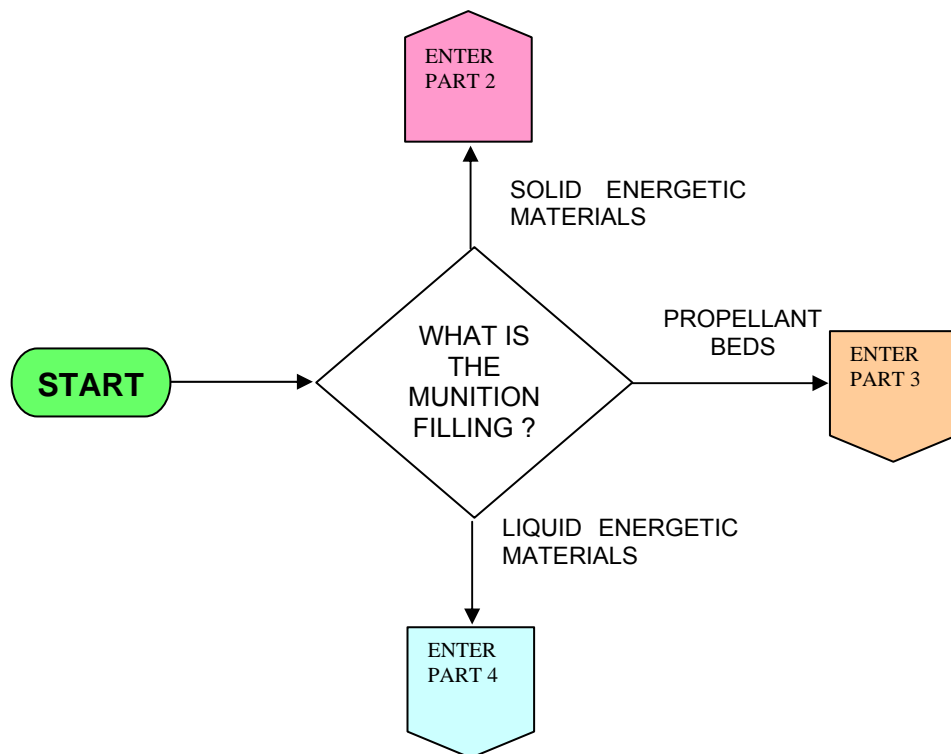

Figure F-2: Shaped Charge Jet Impact Hazard Protocol - Entrance (Part 1)

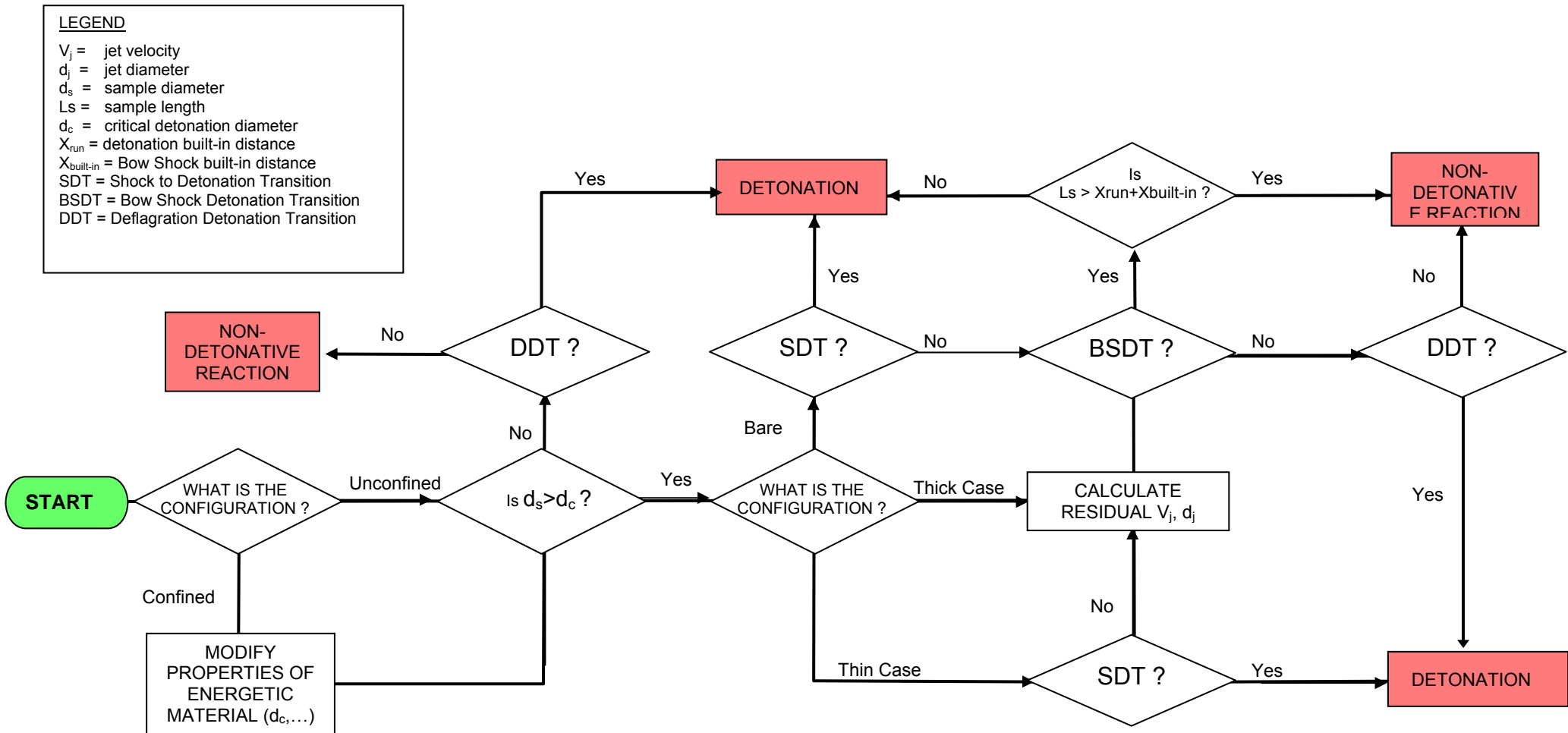

Figure F-3: Shaped Charge Jet Impact Hazard Protocol – Solid Energetic Materials branch (Part 2)

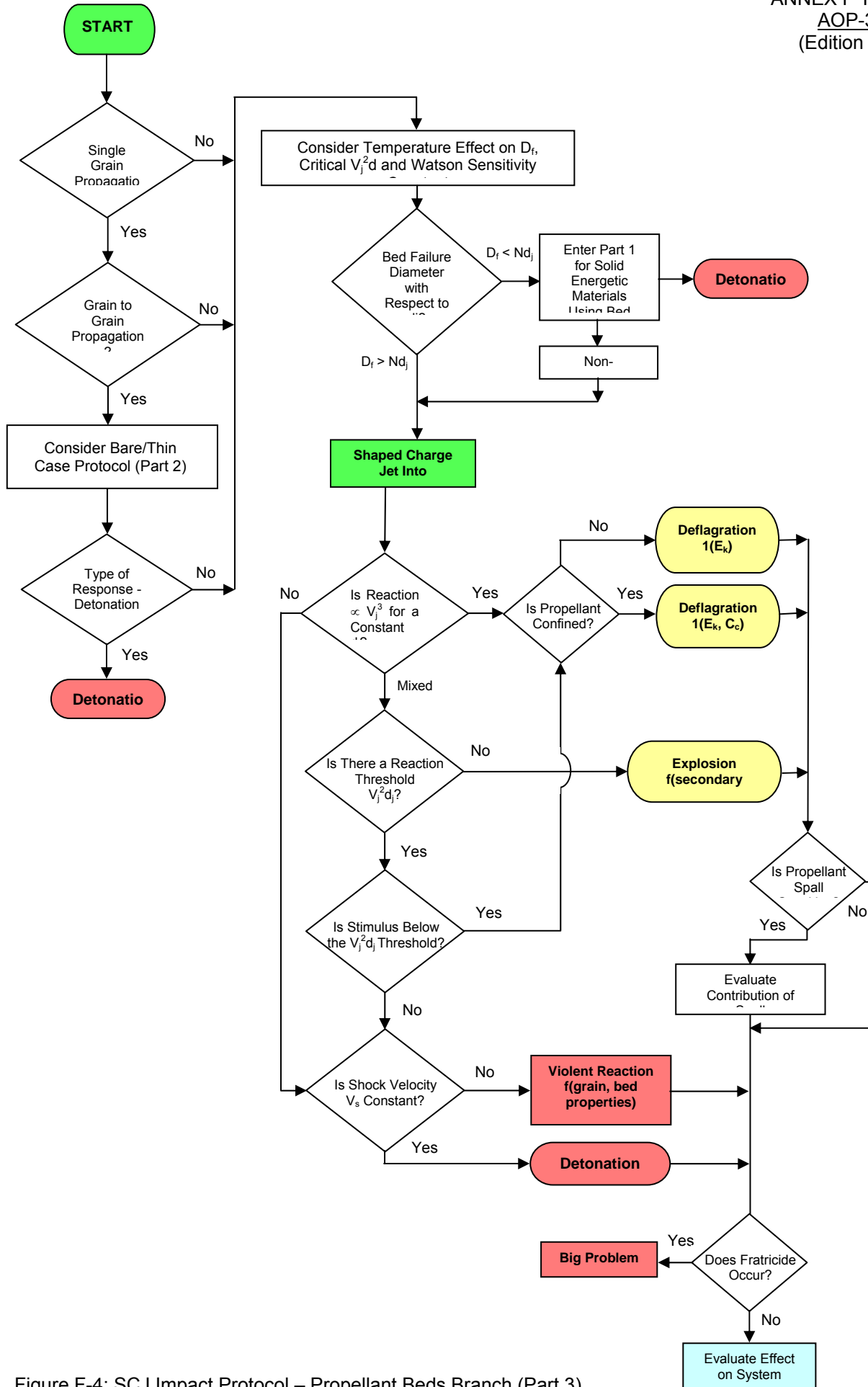

Figure F-4: SCJ Impact Protocol – Propellant Beds Branch (Part 3)

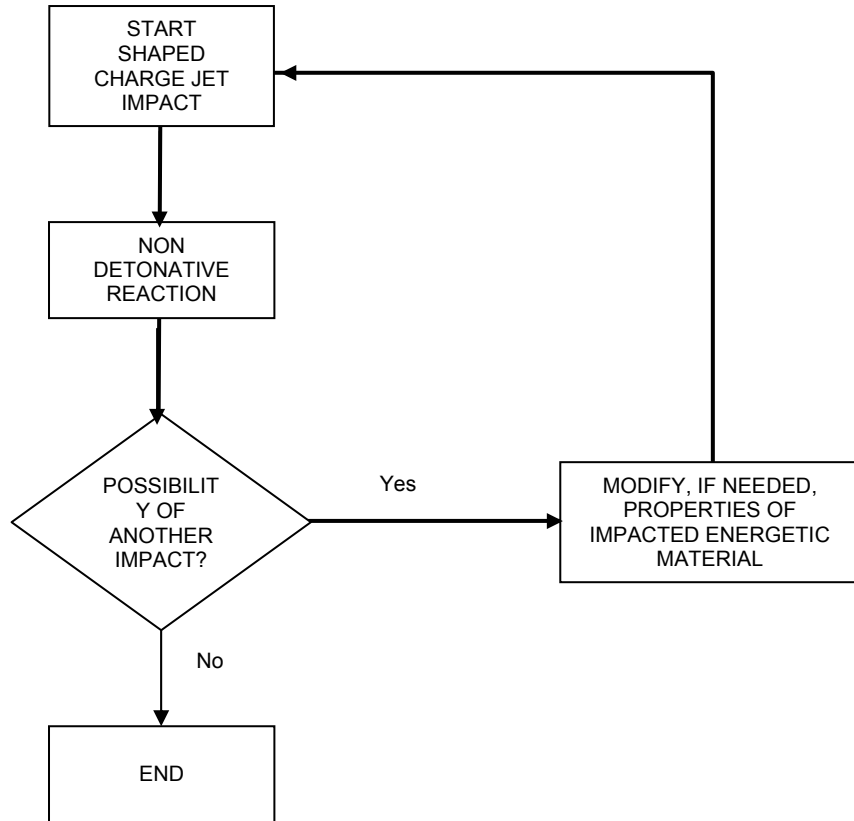

Figure F-5: Shaped Charge Jet Multiple Impact Protocol (Part 5)

TABLE F-1 Examples of tools available and data required to analyse bullet/fragment impact reaction paths

KEY FACTORS/ REACTION MECHANISMS	TOOLS FOR ANALYSIS	PROPERTIES REQUIRED
Shock to Detonation Transition (SDT)	Gap Test Wedge Test Critical Diameter Test Plate Impact Test High Velocity Shotgun Test	Scaling Effects Fragment Characteristics Shock Hugoniot of Energetic Materials and Impactor Shock Pressure and Duration Pop Plot Critical Energy Design Dependent
Penetrate Case / Severe Distortion	Mechanical Properties of Case and Projectile at High Strain Rate Projectile Physical Characteristics (Velocity, Geometry, Mass)	Mechanical Properties of Case and Projectile Geometry and Ballistics of Projectile Ballistic Limit for Case Projectile Break-up and Resulting Fragment Characteristics Design Dependent
Hit Bare EM	No Small Scale Tests Proposed	Design Dependent
Reflected Shock Possible	Plate Impact Test	Design Dependent
XDT	Shock Test of Damaged Material Double-shock Gap Test High Strain Rate Mechanical Properties Testing High Strain Rate Fracture Mechanics Testing	High Strain Rate Mechanical Properties High Strain Rate Fracture Mechanics

KEY FACTORS/ REACTION MECHANISMS	TOOLS FOR ANALYSIS	PROPERTIES REQUIRED
Ignition	Differential Scanning Calorimetry (DSC) or other Test to Measure Temperature of Ignition Hot Ball Test / Hot Fragment Conductive Ignition Test Friction Sensitivity Test Mechanical Properties Testing at Relevant Strain Rates Fracture Mechanics Testing at Relevant Strain Rates	High Strain Rate Mechanical Properties High Strain Rate Fracture Mechanics Kinetics and Thermochemistry of EM Decomposition as a Function of Temperature and Pressure
Significant Material Damage	Friability (Shotgun Test) Tube Test Hopkinson Bar Mechanical Properties Testing at Relevant Strain Rates Fracture Mechanics Testing (Fracture Toughness)	Material Properties Toughness at Appropriate Strain Rates (Fracture Mechanics Properties) Additional Surface Area Generation
Sufficient Venting	Mechanical Properties Testing Burn Rate (at High Pressure) Projectile properties (Velocity, Geometry, Mass, Orientation) Close Bomb Test Ballistic Limit Testing	Highly Dependent on Munition Design High Strain Rate Mechanical Properties Effect of Confinement
Layered Burning (normal surface regression)	Burn Rate (Strand Burner) Closed Bomb Burning Tube Tests Small Scale Motor Tests	Burn Rate as a Function of Temperature and Pressure
Propulsion	No Small Scale Tests Proposed	Dependent on Munition Design

TABLE F-2 .Examples of tests that can be used to generate the data required in Table F-1

DATA REQUIRED	PROPERTIES	TEST TO BE CARRIED OUT	GENERAL POINTS
Kinetics and thermo chemistry of EM physical changes or decomposition	• Porosity	• Density Measurements	• Over a suitable temperature, pressure, dimensions and geometries range including ones resulting from mechanical or/and thermal damages
	• Pore size	• Refractive Matching Fluid • Atomic Force Microscopy • Scanning Electron Microscopy (SEM)	
	• Particle size	• Microsonic Techniques	
	• Crystal quality	• SEM • Microscopical Techniques • X-ray Diffraction • Density measurement test	
	• Chemical reaction rate	• Adiabatic bomb calorimeter • Thermo analytical techniques <ul style="list-style-type: none"> • Differential Scanning Calorimetry (DSC) • Dynamic Mechanical Thermal Analysis • Thermo Mechanical Analysis (TMA) • Thermo Gravimetric Analysis (TGA) • Differential Thermal Analysis (DTA) • Dilatometry 	
Burning rate	• Burn rate (Undamaged and damaged material)	• Strand burner • Closed bomb • Hybrid combustion bomb	<ul style="list-style-type: none"> • Over a suitable temperature, pressure dimensions and geometries range including ones resulting from mechanical or/and thermal damages • Not measured routinely • Highly dependent on damage characteristics • Fractures • Porosity • Dewetting
	• Friability: • Propensity to fracture/damage	• Shotgun test (Friability test) • Bullet damage test • Hopkinson bar • Failure modulus test • Taylor impact test • Fracture toughness	
	• Damage Characterisation	• Sectioning microscopy • X-Ray tomography • Closed bomb (Surface area) • Neutron and X-Ray diffraction • Coefficient of Thermal Expansion	

DATA REQUIRED	PROPERTIES	TEST TO BE CARRIED OUT	GENERAL POINTS
Mechanical physical and thermal properties of munitions individual inert components		<ul style="list-style-type: none"> • Thermal expansion measurements • Thermo analytical techniques <ul style="list-style-type: none"> • Differential Scanning Calorimetry (DSC) • Dynamic Mechanical Thermal Analysis (DTMA) • Thermo Mechanical Analysis (TMA) • Thermo Gravimetric Analysis (TGA) • Differential Thermal Analysis (DTA) • Dilatometry • Mechanical properties analysis <ul style="list-style-type: none"> • Uniaxial Tensile/Compressive Testing (Low Strain Rates) • Servohydraulic Mechanical Test (at rates from 1 to 500/s) • Hopkinson Bar (at Rates from 100 to 10⁴/s) 	<ul style="list-style-type: none"> • Over a suitable temperature, pressure, dimensions and geometries range including ones resulting from mechanical or/and thermal damages
Thermal physical and mechanical properties of munitions EM		<ul style="list-style-type: none"> • Same as in Mechanical physical and thermal properties of munitions individual inert components • AOP-7 test category 102-02-xxx 	<ul style="list-style-type: none"> • Over a suitable temperature, pressure dimensions and geometries range including ones resulting from mechanical or/and thermal damages
Mechanical physical and thermal properties of munitions assembly and packaging		<ul style="list-style-type: none"> • Same as in Mechanical physical and thermal properties of munitions individual inert components • Components bond strength <ul style="list-style-type: none"> • AOP-7 Series 102.01 tests • Compatibility test in an environment representative of IM tests 	<ul style="list-style-type: none"> • Over a suitable temperature, pressure dimensions and geometries range including ones resulting from mechanical or/and thermal damages
Detailed munitions design		<ul style="list-style-type: none"> • Technical Data Package • X-Ray • Munitions disassembly 	<ul style="list-style-type: none"> • Geometry and physical size • Loading density • External confinement • Gas tightness • Free volume • Casing type

FULL SCALE TEST PROCEDURES

Threat	Test STANAG number
Magazine/store fire or aircraft/vehicle fuel fire	STANAG 4240
Fire in an adjacent magazine, store or vehicle	STANAG 4382
Small arms attack	STANAG 4241
Fragmenting munition attack	STANAG 4496
Shaped charge weapon attack	STANAG 4526
Reaction propagation in magazine, store, aircraft or vehicle	STANAG 4396

CONDUCT AND REPORTING OF FULL SCALE HAZARD TESTS

INTRODUCTION

1. Undertaking full-scale IM testing is a complex and expensive process and assessment of the response requires detailed data and expert judgement. Experience has shown that there is a need to provide guidance and advice on the IM full-scale testing and assessment process in order to assist those involved and to improve standards and practices and to maintain them at a consistent high level.

AIM

2. The aim of this guide is to provide guidance on the best practices for designing, conducting and reporting full-scale IM tests.

USERS OF THIS GUIDE

3. This guide is written for the wide range of users who are involved in full scale hazard testing and are responsible for the contracting, conducting, reporting and assessing of IM tests, including safety advisers, scientists, technologists and project staff; in test ranges, industry and at research establishments.

LAYOUT OF THIS GUIDE

4. This guidance is divided into the 3 chronological steps of designing an IM test programme, conducting the trial, and reporting the trial. It also provides guidance on the IM assessment process so far as those involved in designing, conducting and reporting trials are aware of the information needed by those who are responsible for the subsequent assessment of the results. The guide includes a template for reporting IM tests and a list of the issues which need to be considered in designing each of the 6 IM tests.

WHY IM TESTING IS DIFFERENT

5. IM testing differs from all other ordnance and munitions safety testing in that the pass criterion for each test involves an explosive response. For all other safety testing, the pass criterion is that there should be no explosive response at all and the munition is expected to remain safe, either for use or for disposal; it is relatively straightforward to assess whether that criterion has been satisfied. For IM testing, the reaction of the munition under test may range from full detonation to no explosive reaction at all and the different levels of reaction have been classified by NATO as a series of 'Response Descriptors', Type I to Type VI, which are listed and defined in Annex I.

6. The difficulty in full-scale IM assessment is in determining which level of explosive response occurred. Whilst it may be relatively straightforward to determine whether a full detonation or simple burning took place, differentiating between the intervening categories of partial detonation, explosion and deflagration is far from straightforward and requires specific evidence, generally of a quantitative nature, which must be evaluated by expert assessors.

PURPOSE OF IM TESTING

7. The primary purpose of full-scale IM testing is to establish the response of a munition to the unplanned stimuli defined in ANNEX I when tested under specified conditions. This information can then be used as evidence in the assessment to determine whether the munition is IM-compliant.

8. However, there are additional reasons for conducting full-scale IM testing which make an important contribution to the assessment of safety of a munition.

9. IM testing provides a measure of the explosive output from the munition's response to each particular threat. This enables an assessment to be made of the likely collateral damage from the munition's reaction which can be used to evaluate the risk posed by the response of the munition and to inform appropriate mitigation and risk reduction measures.

10. Other purposes of full-scale IM testing include:

- Evaluating the effectiveness of external mitigation concepts such as packaging and barriers.
- During development and technology demonstrator programmes, to establish the IM characteristics of specific design concepts.

11. It is important to note that whilst IM assessment is based on the full body of evidence, full-scale testing is a key component of the assessment process. Because only a very small number of full-scale tests are conducted, the results of which do not have statistical significance and which may not be repeatable, it is essential to take account of the characteristics of the energetic materials and the munition's design, small-scale and component level test results, modelling and theoretical analyses and read across from similar designs. These will provide a good indication of the likely result of full-scale testing. Full-scale testing should thus be seen as a means of confirming the predicted response based on the body of evidence.

12. Full-scale testing also ensures that any full-scale effects which are difficult to model or reproduce at the small- or sub-scale level are properly addressed in the testing and assessment process. It follows that there should be reasonable confidence in the likely outcome of every full-scale test before it is undertaken. This will also play an important role in the design of the test and the selection of appropriate instrumentation.

13. There may also be occasions when there is sufficient evidence from laboratory, small scale and component level testing, energetic material characterisation, modelling and read across, to provide a high level of confidence in the predicted outcome of full-scale testing. In such cases, it may not be necessary or appropriate to conduct a full-scale test and advice should always be sought from the National Authority. This has particular relevance to high cost munitions where there will be a requirement to minimise the number of test items.

IM AND HAZARD CLASSIFICATION

The full-scale tests used for IM assessment are also applicable to Hazard Classification. In the past, IM and Hazard Classification tests have been carried out independently. It has been recognised that this is inefficient and wasteful of resources and the objective today is to test once only for both purposes. Thus in developing a trial specification for IM testing, it is essential to take account of Hazard Classification test requirements. The initial review of test plans should address both aspects. In the processes for undertaking IM testing that are described in this guide, it will be necessary to bear in mind the issues that will arise of achieving hazard classification through combined testing and to seek to obtain any supplemental details that are required.

In accordance with STANAG 4123 and AASTP-3, appropriate munition hazard classification testing per STANAGs 4375, 4240, 4241, 4382, and 4396 shall be conducted and specifically, Procedure 1 of STANAGs 4375, 4241, and 4382 shall be utilised.

THE TRIAL FRAMEWORK

INTRODUCTION

1. This section describes the key factors in setting out the trial framework. Clear objectives and responsibilities are essential to provide the basis for a successful IM test programme and must be established before proceeding to the detailed work of designing the individual tests within the programme.

SETTING OUT THE TRIAL FRAMEWORK

2. Determining Trial Objectives

2.1 The first step in designing an IM test programme is to make a clear definition of the trial objectives. Normally there will be 2 overall objectives: to determine the response of the munition to the IM stimuli and to demonstrate compliance with a Nation's IM Policy. These objectives are not the same. It is important to establish the response of the munition to the IM threats even if non-compliant. This information is needed for safety, risk and vulnerability assessment and to inform any mitigation measures which may be needed to reduce risk to As Low As Reasonably Practicable (ALARP).

2.2 There may also be a variety of additional reasons for undertaking full-scale IM testing. Examples include:

- To determine time to response.
- To determine the effectiveness of different types of packaging and mitigation schemes.
- To determine the IM response of alternative filling and fuzing compositions.
- To determine the IM response using different munition design characteristics such as case material, case thickness, coatings and barriers, initiating devices, venting devices.

2.3 The trial objectives should also state how the results are to be assessed, who by, and define the acceptance criteria. For full-scale tests to demonstrate compliance with a Nation's IM Policy, the acceptance criteria will be achievement of a response against each relevant IM threat no worse than as stipulated in STANAG 4439.

3. Formation and Duties of Trials Planning Group

3.1 A project-based Trials Planning Group (TPG) will normally be established by the design authority at the outset of each munition programme. This should include representation from the project team, the relevant safety authority and, where appropriate, relevant specialists from research establishments and the test facility. The TPG will provide a collective overview of, and input to, all tests and trials relevant to IM and will contribute to ensuring that a full body of evidence is obtained from which both achievement of the contracted levels of IM compliance and compliance with the nation's IM Policy requirements (if different) can be assessed.

3.2 The activities of the TPG should extend to ensuring a Trials Readiness Review is held, ideally for each trial, to ensure that all aspects of the testing are sufficiently established to the satisfaction of all stakeholders and the tasking to the test agency has been effective in communicating the many items of detail involved. A trials compliance check sheet is a useful document for all concerned at the Trials Readiness Review. This gives satisfaction to all involved, not only the tasking and tasked staffs, that the trials and data collection are to be conducted as agreed, including allowing any waivers or amendments to original requirements to be recorded.

4. Responsibilities of the Project Team

4.1 The project team is responsible for ensuring that the contractor's IM test plan will provide sufficient evidence from which assessment can be made both of compliance with the contract requirements for IM and of compliance with the nation's IM policy requirements.

4.2 The project team is responsible for submitting the IM full-scale test plan to the National Authority for review before full-scale testing takes place and for presenting the results for formal assessment on completion of testing. This should normally take place within 3 months of an individual test or, for a test programme, within 3 months of completion of the final test in the programme. In addition to the test results, the national authority will require additional information on the munition's design, energetic materials and function. The project team is therefore responsible for providing guidance to the munition contractor on the application of this guide.

5. Responsibilities of the Test Agency

5.1 The test agency is responsible for carrying out the IM test programme in accordance with the test plan. If it becomes necessary to deviate from the conditions/parameters stated in the plan, the test agency should seek the agreement of the project team, who as necessary will seek specialist advice from the national authority.

5.2 The test agency is usually responsible for writing the test report. Since the test report is the permanent record of what occurred and plays a vital role in the assessment of the result, it is essential that the test report is comprehensive and contains all the information necessary to make an objective assessment. Guidance on how to construct a test report is included in Appendix 1.

DESIGNING THE IM TEST PROGRAMME

INTRODUCTION

1. This chapter describes the key factors in designing the IM test programme. Clear and well-considered test plans are essential to a successful IM test programme and the more effort that is devoted to the planning stage, the greater the likelihood of a successful outcome.

USE OF SPECIFICATIONS/STANAGs

2. The starting point for any IM trial is the relevant test STANAG. It is important that the latest edition is used. Where a contract calls up an edition current at the time the contract was placed, but a later edition is issued before testing takes place, wherever possible the testing should be adjusted to take note of any changes reflected in the later edition.

SELECTION OF TEST ASSETS

3. Design Standard

3.1 For full-scale IM testing, which is undertaken at the end of the development cycle to establish compliance with the Nation's IM Policy and with contract requirements, the munition under test, and any packaging, should always be fully representative of the final design standard.

4. Live and Inert Components

4.1 Ideally, the munition under test should be the complete item. For example, the various components of the explosive train may have a significant effect on the response of the munition and omitting one or more may result in an unrepresentative response.

4.2 However, there is little point in destroying expensive electronic components if these will not have any influence on the test response. Thus such components can be replaced by thermally, mechanically and geometrically representative inert components, provided that the thermal characteristics of the test munition and the mechanical confinement of the explosive components remain unchanged.

4.3 Where a munition has a removable fuze (e.g. artillery shell), the decision to test with or without the fuze fitted will depend on the configuration appropriate to the threat assessment and life cycle. For stores with a fixed fuze, it is not normally acceptable to test with an inert fuze.

5. Use of Environmentally Conditioned Munitions

5.1 There is no specific rule whether the munition under test should be factory-fresh, un-aged and in pristine condition or whether the munition should have been subjected to some accelerated ageing and/or environmental conditioning. Both are acceptable.

5.2 Use of new munitions can provide a useful baseline whilst use of aged/environmentally conditioned stores may provide closer representation of the condition of the munition when likely to be exposed to the IM threats in-service. Guidance should always be sought from specialists.

PRODUCING TEST DIRECTIVES (INSTRUCTIONS)

6. The test directive contains all details and instructions necessary for successful completion of the IM testing and should stand alone. It is the responsibility of the munition Design Authority to produce the test directive, which will normally be submitted to the project team for approval as specified in the contract.

7. The project team should seek the advice of safety advisers and relevant technology specialists. It is the project team's responsibility to seek the review panel's endorsement of the test directive before the testing takes place.

8. Specifying Test Parameters

8.1 In developing the full-scale test parameters, use should be made of all available information from earlier development testing and analysis such as modelling, laboratory and small scale tests, component level tests, characterisation of the energetic materials and from read across of IM test results from other munitions with similar design characteristics.

8.2 This body of information should be used both to make an assessment of the likely response of the full-scale test and to determine specific test parameters and conditions. Where the appropriate test STANAG offers a choice between a standard and a tailored test, this information may be relevant to deciding which to choose.

9. Establishing Test Configuration

9.1 The threat assessment should provide the necessary advice on the munition configuration to be adopted. There are also a number of practical considerations which affect the choice of configuration for IM testing which are discussed in the following paragraphs.

10. Packaged vs. Unpackaged

10.1 The size and NEQ of a munition is an important consideration in determining the configuration in which the munition should be tested.

10.2 For small stores, such as pyrotechnics, CADs and PADs, small arms and cannon ammunition, which normally spend most of the life cycle packaged and are only unpackaged at the point of use, testing against all IM threats should be done in the packaged configuration. It makes little sense to conduct a Bullet Impact test against a single bare 20 mm round, whereas a Bullet Impact test against a full container of 100 rounds provides valid information about the response of the munition in the configuration in which it is most likely to be exposed to the threat and the configuration from which the greatest risk of collateral damage is likely to result.

10.3 For larger munitions, the threat analysis will determine the required configuration; in some instances it may be necessary to conduct a particular test in both the packaged and unpackaged configurations. It is usual to test for impact threats against larger munitions unpackaged.

10.4 The ability to determine the response may also be a factor in determining whether to test packaged or unpackaged. For example, in the slow heating test, where the test item is enclosed in a test oven, which itself will mask some of the effects of any reaction, to test in the packaged configuration may render it impossible to make an accurate assessment of the reaction. In such cases, far more useful information may be obtained if the item is tested unpackaged even though this may not be the configuration indicated by the threat assessment.

11. Component Level or AUR

11.1 The decision whether to test at AUR or component level will depend on a variety of factors. The first is the size of the munition. Small munitions will invariably be tested as an AUR, usually packaged. It is only the larger munitions such as missiles, incorporating both warhead and motor(s), where the option to test at component level arises.

11.2 For the thermal threats (Fast and Slow Heating), it can be useful to conduct tests at component level so that the response of each major component can be clearly determined in isolation. However, there may be interaction between the components which would lead to a different response and therefore it is usual to conduct an AUR test as well.

11.3 For the impact tests (Bullet, Fragment and Shaped Charge Jet), it is standard practice to conduct the tests at component level and the most violent response is then ascribed to the AUR.

11.4 Sympathetic Reaction tests may be conducted at component level to determine the response and inform mitigation, for example to determine the need for mitigating barriers between missile warheads or between missile motors. However, AUR tests will normally also be required in the packaged configuration unless the response can be assessed with confidence from the component level tests. There are examples in which detonation of a donor rocket motor has caused the warhead of an adjacent munition to detonate and vice versa.

11.5 Additionally, it is always necessary to consider the effect of the energetic or mechanical reaction from the component which reacts first onto the other components in the missile, e.g. from warhead reaction causing motor initiation; or from functioning/arming resulting from flight or propulsion of the munition, etc.

11.6 Where it is decided to test at component level, it is important to ensure that the component is in a configuration representative of the AUR. For example, if a thermal test is to be conducted on a rocket motor, omitting the external structure around the nozzle and blast pipe may reduce mechanical confinement and allow the nozzle assembly to be ejected from the motor with a consequently less violent explosive reaction than if the nozzle assembly had remained in place.

TEST CONSIDERATIONS

12. Package to Package Propagation.

12.1 For sympathetic reaction, the objective is to establish both the level of response and whether there is propagation of reaction from one item to another. For smaller stores, the package can be considered at the "item" and the requirement is thus to assess package-to-package propagation. Too often, the test is only conducted with a single package which may provide inadequate information.

12.2 If the reaction effects are contained within the single package, then it is clear that there will not be package to package propagation and no further testing is needed. However, if there is disruption of the package, then the effect on adjacent packages will need to be tested and assessed.

13. Aim/Impact Points

13.1 For the impact tests (bullet, fragment and shaped charge jet) it is important to select appropriate aiming points. Bullet impact should normally be carried out against both the most sensitive component/energetic material (eg motor igniter, warhead booster) and against the main charge filling. "Most sensitive component" should taken to mean the component which, if exposed to the threat, is likely to lead to the most violent response of the munition. It is important to be realistic about probability of this component being struck by the threat; for a very small booster or initiator buried deep within the munition, the chances of this being struck may be remote and there may be little point in attempting to do so in a test. In such cases, it is far more relevant to attack the main charge filling.

13.2 It is also important to consider the likely response of the “most sensitive component”. For a rocket motor, if attacking the igniter can confidently be predicted to lead to ignition of the motor in the design mode, there seems little point in conducting a test just to prove the point. For fragment and shaped charge jet impact, it is the reaction of the main charge filling which is of concern, in particular whether it can be shocked to detonation, and there may be little point in attacking the booster or igniter. Every test must be evaluated separately, using advice from specialists, to ensure that appropriate aiming points are selected, with appropriate tolerances to reflect the difficulty of achieving absolute precision in aiming.

14. Method of Initiation

13.1 For Sympathetic Reaction, it is particularly important to select an appropriate means of initiating the donor munition.

- For warheads, detonation in the design mode is the normal procedure. This is often achieved by removing the safety and arming device and initiating the booster explosive electrically.
- For rocket motors, a shaped charge is normally used to attack the motor propellant through the casing.
- For non-detonable stores such as pyrotechnics and CADs and PADs, functioning of the donor in the design mode is appropriate.

15. Restraint and Tethering

15.1 Where it is expected that a munition may become propulsive as a result of the test stimulus, it is likely to be necessary to restrain the munition to minimise the hazard to the test range and personnel. There are various ways in which this can be achieved. For example, the munition can be contained within a cage or within a concrete block enclosure, the munition can be clamped to the test stand, or the munition can be restrained by some tethering device such as a steel chain or cable.

15.2 Whatever method is used, it is essential that the restraint does not influence the response of the munition in any way thus leading to a false result. Cages and barriers can influence or invalidate blast overpressure readings and can prevent accurate measurement of debris throw.

15.3 For missiles, it will normally be important to establish whether propulsion occurred and some measurement of thrust will be required; the method of restraining the test item must not prevent measurement of thrust and confirmation of propulsion.

16. Pre-Conditioning

16.1 Full-scale IM tests are normally undertaken on test items at ambient temperature, unless there are specific reasons for pre-conditioning the item at either a higher or lower temperature. Testing at high or low temperature may result in a different response, for example due to embrittlement at low temperature and softening of the energetics and weakening of the case at high temperature.

16.2 However, if the threat analysis shows that a particular threat is most likely to occur at a high or low temperature, then it may be appropriate to test at this temperature.

16.3 The thermal tests (Fast and Slow Heating) should always commence with the test item at ambient, noting that the slow heating test allows rapid pre-conditioning to a higher temperature as part of the test procedure. In this latter case, it is often most useful and effective to precondition the munition and the oven together.

17. Marking and Colouring

17.1 For Sympathetic Reaction, it is essential to be able to distinguish between the debris of donor and acceptor munitions. Consideration should be given to colour coding the acceptors, for example by painting the external surface of each acceptor munition a different colour.

18. Re-use of Test Item if No Reaction

18.1 For impact tests in which the test item has not reacted at all, it may be possible to reuse the test item for a further impact test. This will depend on the amount of disruption caused to the munition or case and consequent reduction in confinement of the energetic material.

18.2 If it is assessed that the bullet or fragment entry (and exit if appropriate) holes from the first test will have little effect on the results of a subsequent test, then the test item can be re-used.

SELECTION OF APPROPRIATE INSTRUMENTATION AND RECORDING

19. Fast Heating

19.1 In the fast heating test, it is necessary to measure the flame temperature, both to establish the starting point for measuring the time to reaction, taken from the time that the flame temperature reaches 550°C, and to measure the average temperature from the time that 550°C is achieved until all munition reactions are complete; The average temperature must exceed 800°C for the test to be valid.

19.2 It is necessary to use at least 4 thermocouples with a sampling rate greater than 0.2 Hz.

19.3 The temperature from each thermocouple should be recorded throughout the test.

19.4 Type K thermocouples (nickel-chromium/nickel-aluminium conductors), sheathed in inert hermetically sealed insulation and capable of withstanding 1200°C, are typically used to measure test temperatures.

20. Slow Heating

20.1 In the slow heating Test, it is necessary to measure both the surface temperature of the test item and the air temperature within the test chamber.

20.2 Where it is possible to get access to the interior of the test item without altering the test item, interior temperatures should also be measured.

20.3 In general, there should be at least two thermocouples mounted in pairs on opposite surfaces of the test item, one each in the air space near the air inlet and exit, and one each in the air space on opposite sides of the test item that will be expected to react first.

20.4 Temperature from all thermocouples should be recorded as a function of time throughout the test, being sampled at least once per minute.

21. Thermal Flux

21.1 Thermal flux measurement as response discriminator is problematic as heat flux depends on the size of the munition and its shape and is likely to be directional. Therefore, it is not included in the primary or secondary evidence for any reaction level and is not mandated by the IM test STANAGs.

However it is a very useful metric in establishing the collateral damage from the reaction of a munition, and in building the overall safety case.

21.2 The 1997 NIMIC Workshops on IM Testing made the recommendation that, in addition to assessing response type, thermal flux, fragment throw and blast overpressure at set distances (5 m, 15 m, 50 m) should be recorded to provide a quantitative measure of the collateral damage.

21.3 For small stores, where the heat flux will be significantly lower than for a large store, it is suggested that these distances should be reduced to 2.5 m, 5 m and 15 m. Two rows of thermal flux gauges should be sited orthogonally to record the heat output from the reaction of the test item.

21.4 In the fast heating test, it is recognised that the fire itself will generate significant thermal flux readings but it is often possible to identify any increase in the total flux due to the reaction of the test item.

22. Blast Overpressure

22.1 Although not mandated as a primary evidence descriptor for all reaction levels, blast overpressure is a key parameter in assessing response type, and should be measured in all IM tests.

22.2 It is important to estimate before the test the likely response of the munition and the associated blast overpressure so that gauges of appropriate scale can be used. It can also be useful to calibrate blast overpressure measurement by measuring the output of the detonation of a single munition; this will provide a baseline for comparison in subsequent IM tests and will identify the contribution of the donor munition in Sympathetic Reaction.

22.3 Blast overpressure gauges should normally be sited at 5, 10 and 15 m unless either a low-order response is expected or the munition under test has a small NEQ, in which case the distances can be reduced to 2.5 m, 5 m and 10 m. It is important to maintain these standard distances for siting the pressure gauges to provide a basis for comparison between tests and munitions.

22.4 At least 2 rows of blast overpressure gauges, sited orthogonally, should be used in every test, despite some of the IM test STANAGs not having made this a mandatory requirement.

22.5 In the Sympathetic Reaction test, it is important to site the blast gauges such that they have the greatest opportunity of recording the output from the acceptor(s) rather than from the donor.

23. Ionisation Probes

23.1 Ionisation probes can be used to measure the velocity of propagation of the reaction in a munition, which in turn can give an indication of whether a munition has detonated. This can also be useful in confirming that the donor munition in a Sympathetic Reaction trial has achieved full detonation.

23.2 However, the use of ionisation probes has limitations. For example, they are only effective in measuring the velocity of propagation when the reaction starts at a single point in a munition. In sympathetic reaction, for example, the acceptor munition will normally be impacted along its length by the shock, blast and fragmentation from the donor and it is unlikely to be possible to obtain any meaningful record of velocity of propagation.

23.3 The utility of ionisation probes in discriminating between lower order reactions is also less clear, and on their own it is unlikely that the probes will provide sufficient information to make any assessment.

24. Witness Plates

24.1 Witness plates can be extremely valuable in discriminating between reaction types. The amount of pitting, marking and indentation can show quite clearly whether a munition has detonated (many witness marks from the fragmentation of the munition case and deformation due to blast) or has experienced a lower order reaction (fewer witness marks, minimal deformation, through to no marking at all).

24.2 Witness plates also have the benefit of providing a permanent record which can be examined in detail after the test, and should be strong enough to withstand detonation of the test item.

24.3 The optimum material to use for a witness plate depends on the type and velocity of the expected fragments. For heavy munitions with steel walls, a steel witness plate with a thickness of at least 25 mm is recommended. However, for munitions with aluminium skins or very thin steel skins, an aluminium witness plate may provide better results. For munitions with plastic or composite skins, witness plates may not be useful.

24.4 It can be useful to site witness plates beneath and on 2 or 3 sides of the item under test, at a suitable stand-off distance. Normally, witness plates should not be in direct contact with the test item since this might alter the heat flow into the round and the confinement of the energetic material. Ideally, there should be at least 200mm between the witness plate and the test munition so as not to interfere with the uniform heating of the munition.

24.5 It is important not to screen other instrumentation such as blast overpressure gauges or to restrict the throw of debris, whilst at the same time being close enough to the test item to obtain a meaningful record of fragmentation and blast damage.

24.6 In Sympathetic Reaction tests, it is useful to position a witness plate adjacent to or beneath the donor as well as the acceptors, so that the witness damage from the full detonation of the donor can be compared with that of the acceptors.

25. Fragment Throw, Velocity and Mass

25.1 One of the key determinants in assessing response type is the size and mass of the debris (fragments, casings and any other items generated by the tested munition) and the distance it has been thrown from the site of the test. In a detonation reaction, the case of the munition will be shattered into very small pieces and projected considerable distances, and all energetic material will be consumed; as the response type reduces in severity, so the munition fragments will increase in size, the amount of unconsumed energetic material will increase and the distances over which debris is projected will reduce.

25.2 A detailed debris map is an essential element of the report of any IM test. The map should show the location of each significant item of debris, recording its identity, mass and distance thrown. In order to achieve this, it is essential that the test arena is cleared of all debris from previous tests before any test is performed. The surface of the arena should ideally be smooth and hard, such as concrete or rolled sand; if the arena is grass covered, it should be cut as short as possible.

25.3 Access to all areas of the arena is essential for debris plotting and identification. Where test arenas overlap with other range safety traces it will be necessary to co-ordinate test activities to ensure that the necessary access is obtained.

25.4 Once debris mapping is complete, the debris should be collected and photographed; where more than one munition has been tested, debris should be separated and grouped by individual munition. The total weight of debris recovered per individual munition should be recorded, so that it can be compared with the original weight of the test item.

25.5 Fragment size and velocity can also be measured using absorbent material, such as strawboards, fibreboards or soft plaster panels to catch the fragments without breaking them. It is usual to have a number of layers which can be separated after the test. The fragments can be

recovered, identified and weighed and the depth of penetration can be used to calculate fragment velocity.

25.6 Strawboards (or equivalent) should be sited at set distances from the test item; 5 m and 15 m are recommended, to provide a standard. The strawboards should be sited on opposite sides of the test item along the axis representing the line of greatest fragmentation. For a bursting store such as an artillery shell, this will be at right angles to the body of the shell but for a munition which has a directional fragmentation pattern, it will be necessary to select an appropriate worst-case axis.

26. Photographs and Video

26.1 Photographic and video evidence is vital to assessment of IM response. High speed photography should be used for all trials so that the test can be played back for analysis after the test.

26.2 In siting the camera(s), it is important to ensure that the field of view will not be obstructed by any of the test facilities or instrumentation and that the field of view will include all necessary information. For example, if it is expected that a rocket motor under test will exhibit propulsion, it is important that the field of view includes an area to the rear of the motor nozzle so that it can be determined whether a plume with shock waves has formed.

26.3 Ideally, there should be one high speed video giving an overall view of the test arena, which will include capture of debris throw and a view of any fireball that forms, and a second video giving a close up view of the test item.

26.4 Still photography should be used to record the test set up before the test. This should include general shots of the test arena and test stand, close ups of the test item including, for packaged items, a shot of the contents of the container with the lid removed to show packing method and orientation of test items, and close ups of the test item(s) on the stand. For impact tests, include shots showing the aiming point.

26.5 Post test, still photography should be used to show the test stand and remains of the test item, close ups of the witness plates, of any craters formed and of all significant items of debris including unreacted energetic material. It is important that the debris in each photograph is clearly identified in the subsequent report.

27. Measurement of Thrust (for Propulsive Reactions)

27.1 Measurement of thrust has rarely been attempted in past IM tests. However, as munitions become increasingly IM compliant and burning reactions rather than explosive reactions become the norm, so the likelihood of a propulsive reaction from a rocket motor under test becomes greater.

27.2 It is important for assessment of safety to determine whether a motor does become propulsive and whilst the formation of a plume and shock waves is perhaps the clearest indication, measurement of thrust is important for those occasions when the visual indication is inconclusive. Examples of techniques to measure thrust include the installation of a pressure transducer in the motor suspension arrangement on the test stand or between the nose of the motor and the wall of the test chamber.

27.3 For fast heating tests, it is unlikely that electronic measurement devices will withstand the 850+°C to which the test item is exposed; it may be possible to allow the motor to move a short distance on its stand to impact and indent a witness screen so that, from a measure of the depth of indent, the energy of the motor at impact can be calculated. This would probably require the motor to be restrained in some way (e.g. by a chain or steel cable or by being confined in a cage) to ensure that it did not leave the hearth, but the method of restraint must not affect the heat transfer to the munition or the confinement of the munition.

28. Sound

28.1 It is important to record the sound throughout the test. All explosive events will be accompanied by sound and these can help to differentiate between the sharp crack of a detonation and the more prolonged sound of an explosion

28.2 Sound is particularly valuable when the test item is obscured from view, for example by the smoke and flame from the fast heating hearth or by the slow heating oven, or when the item is being tested packaged and multiple events are occurring within the package. A microphone should therefore be placed at an appropriate distance from each test item to record the sounds of any reaction.

APPROVAL OF TRIAL SPECIFICATION

29. All IM test plans should be agreed by the national authority before testing takes place. The objective of this review is to ensure that all aspects of the test plan are in accordance with best practice and that the test will achieve its objectives.

30. It is the responsibility of the project team to submit the test plans to. The project team and will normally have consulted safety advisers and science and technology specialists in the development of the test plan, making the formal review a straightforward process. To enable proper consideration and to ensure that there is time to incorporate any changes which the review body suggests, it is important that the final test plans are submitted for formal review as early as possible and in good time before the Trials Readiness review and actual testing is due to take place.

CONDUCTING THE TRIAL

CONDUCTING THE TRIAL

1. The trial should be conducted in accordance with the trial directive in a methodical and structured manner. Most IM tests will result in the destruction of an expensive test item, require the gathering of a large amount of transient data and it may not be possible to repeat the test. It is therefore essential that all aspects are completed satisfactorily.

2. Site Layout and Pre / Post Test Clearance

2.1 The layout of the test site and instrumentation must conform with the trial directive. It is essential that any debris from previous tests is cleared from the site before testing takes place.

2.2 Consideration should be given before the test to the level of response expected and the likely size and distance that debris will be thrown to ensure that a sufficiently large area is cleared.

2.3 Ideally, the surface of the test site should be concrete or firm sand, to enable location of debris. Where the test site is grass covered, this should be cut as short as possible.

3. Instrumentation and Recording

3.1 Instrumentation should be set up as detailed in the trial directive.

3.2 It is important that all instrumentation is appropriately tested and calibrated before the test and that all cabling and wiring is adequately protected so that there is no risk of vital connections being cut by the effects of an explosive reaction from the test item and vital data being lost.

4. Witnessing the Test

4.1 The test will normally be witnessed by representatives from the manufacturer, the project team and by the safety advisor. The project team may invite appropriate specialists, representatives from the review body, independent safety auditors and from the research establishments, to attend and witness the test.

4.2 First hand information from those witnessing the test can prove very valuable the assessment process, and it is important that all witnesses make appropriate notes and records for subsequent input to the body of evidence which will inform the assessment process.

5. Verification of Compliance with Test Directive and Trial Objectives

5.1 It is essential that the test is conducted in accordance with the test directive; one of the responsibilities of the project team is to confirm compliance.

5.2 Where deviations from the agreed test directive or the procedure concurred at the Trial Readiness Review prove necessary, these must be approved on behalf of the review body by the appropriate project team representative, taking advice as necessary from the safety advisor and technical specialists.

REPORTING THE TRIAL

THE TEST REPORT

1. It is standard practice for the test agency to produce a report of the test. This report may stand on its own or it may form the key input to a report from the Contractor or the Trials sponsor.
2. Where the Contractor or trial sponsor produces a report, this should include comments and observations as appropriate on the test house report and include confirmation that the requirements of the test have been achieved.
3. In making an assessment of the response, the review body will need to review both the test house report and the Contractor or trial sponsor's report. An example of a test report layout and the minimum content to be included is at Appendix 4.

Report Writing

4. Once a full-scale IM test has been completed, the test report and the photographic/video records are all that remain from which to assess the level of response. Since some level of explosive response is expected from IM tests, unlike all other munitions safety tests where no reaction is expected, it is essential that full details of the reaction of the munition are included in order that an informed assessment of the response can be made.
5. The report is a key element of the audit trail for the IM assessment which is likely to be referred to over the life of the munition and it must therefore contain information which is relevant, adequate, accurate and unambiguous.

Instrumentation Records, Measurements and Observations

6. All instrumentation records, measurements and observations (including those by witnesses) must be retained after the test as part of the dossier of evidence for review and assessment. This may include information in excess of that which is contained in the trial report.

Test Report Submission - Timescale, Approval and Acceptance

7. The test report should be submitted to the project team as soon as practicable, and not later than 3 months after completion of the test. It is important that the formal assessment takes place whilst all those involved in the testing are still in post and available and whilst the events of the test remain fresh in the minds of those attending.
8. The project team will confirm that the test report meets the required standard and formally accept the report from the contractor. Where there are shortcomings in the report, the project team may require the report to be re-written, which will delay the acceptance and assessment process; it is in the interests of all concerned that the report should be of a satisfactory standard from the outset.

Test Report Configuration Control and Archiving

9. It is important that each test report can be clearly identified and referenced. There have been examples of programmes where extensive development testing has taken place and it has proved difficult to identify whether individual reports refer to the same or different tests.

10. If a report is changed or updated, it is important to identify the revised report accordingly. It is essential to retain all information relating to a full-scale test in a dossier; this will include the test report(s), photographs, cine and video records and any additional instrumentation records not included in the test report.

11. This dossier of evidence should be retained by and archived appropriately by the project team so that it can be accessed as necessary throughout the in-service life of the munition. Ideally, as electronic reporting becomes the norm, it should be possible to retain most of the relevant information on CD or DVD.

TEST REPORT TEMPLATE

1. The essential elements of an IM test report are described below. The precise format may vary depending upon the requirements of the customer and the standard procedures of the Test Facility.

2. The elements listed here are the absolute minimum and whilst reports should be as concise as practical, it is better to include information which may not be relevant than to omit information which may be relevant. Thus, where there is doubt, the author of the report should include information rather than omit it.

Executive Summary

- A one-page summary describing the test and concluding with an initial assessment of the response.

Introduction

- Background giving reason(s) for test, test sponsor, place and date of test, test procedure.
- Aim and Objectives of test
- Test Officials
- List of those attending the test

Test Equipment

- Identify all equipment used for the test. This will typically include:
 - Explosive stores, design standard, details of any inert components and packaging with diagrams and photographs of the test items before test
 - Exploded diagram of the packaged store (for packaged tests, to show packaging configuration and internal furniture)
 - Ancillary equipment (eg firing device for bullet and fragment impact)
 - Firing/Initiation System (eg detonator or shaped charge jet warhead to initiate donor in Sympathetic Reaction)
 - Instrumentation - list of all instrumentation used
- Test Procedure
- Test Configuration

Describe the test site and layout of test item, including test stand and method of fixing test item to the stand, and instrumentation. It is essential to include a diagram showing test arena, location of test item, position of witness plates, blast screens and similar devices, and all instrumentation with relevant distances. Include colour photographs of the test set up to show both general arrangement and close up details of the test item and how it is mounted.

Calibration

- Include details of any calibration tests, for example to be used as comparative evidence, to achieve correct impact velocity and impact location for bullet and fragment impact.

Safety Measures

- Include details of range safety measures taken to protect personnel.

Results

- Describe the test in detail, including a diary or time log of events where appropriate (eg for Fast and Slow Heating). In particular, describe the reaction of test item. Include:
 - Details of all instrumentation measurements, temperature records and blast overpressure records.
 - A “pen picture” of how the test item reacted.
 - A debris map identifying all ejected debris, location and distance from test position.
 - Photographs of the test item post test and photographs of debris, the test site (to show damage and cratering) and of witness plates and screens. Label each photograph to clearly identify the subject, in particular the precise nature of the debris. Where the test has been conducted packaged and the lid of the container has remained in situ, include internal photographs with the lid removed but indicate that the lid was removed post-test. Include any post-test X-ray photography to determine condition of test items.

Meteorological conditions

- Record the relevant prevailing met conditions at the time of the test (eg wind speed, temperature).

Disposal of explosive items

- Include a brief statement of how the explosive test items were disposed of.

Conclusions

- A short summary of the results of the test and an initial assessment of the reaction Type, including rationale for the assessment such as all data used as comparative evidence e.g. blast over pressure from the detonation of a single munition calibration, etc

References

- Should always include test directive and test procedure (eg test STANAG).

ISSUES RELEVANT TO SPECIFIC TESTS

1. Each of the IM test STANAGs currently includes guidance on the configuration and set up, instrumentation and conduct of each full-scale IM test. It is expected that in due course much of the guidance information in the test STANAGs will be transferred to AOP-39.
2. Information relevant to each of the IM tests has been widely debated within the NATO forum and, following the 1997 NIMIC Workshops on IM Testing, a NIMIC Report was presented to a joint meeting of AC/258 and AC/310 (now subsumed into AC/326).¹ One of the main recommendations of the workshop was the need for quantitative data – subjective and qualitative data should always play a lesser role.
3. This and other NIMIC reports, together with the information in the test STANAGs, form the basis for this Annex, which identifies the issues relevant to each of the IM full-scale tests. It is guidance rather than mandatory lists, but is intended to assist those responsible for developing IM test directives as well as those witnessing and conducting testing to ensure that all possible issues have been considered. It should always be read in conjunction with the relevant test STANAG.

¹ The Proposed Full Scale Test Procedures for IM Testing, NIMIC O-46 dated 26 Jan 99.

FAST HEATING - ISSUES TO BE CONSIDERED

1. Test Item Configuration

1.1 The test item configuration should be determined by the threat assessment. It should represent the configuration of the item appropriate to the life cycle phase being duplicated by the test. This may be packaged or unpackaged and it may on occasions be necessary to conduct a particular test both packaged and unpackaged. For small stores, the test will invariably be conducted packaged. If this is to be combined for IM and Hazard Classification purposes, a test of the packaged configuration is required consisting of three packages or a volume of packaged test items not less than 0.15 cubic meters (whichever is greater).

1.2 The test item should be to the full production standard. Non explosive sections of the item need only be geometrically and thermally representative.

1.3 The use of simulants, dummy units or structures may affect heat flow patterns. If used, these should exhibit closely comparable behaviour to those of the actual items they replace.

1.4 Complex electronic units should be thermally simulated only if it can be demonstrated that there is no possibility of the test environment causing the unit to produce a spurious signal capable of initiating a firing circuit.

1.5 Test fixtures and support stands should make minimum line contact with the test item and must not screen it from the enveloping fire. The test item should be supported to allow for any sagging likely to occur.

1.6 The test item should be mounted with its longitudinal axis horizontal such that the initial height of the bottom of the test item above the fuel surface at the start of the test is at least 0.3 m. The height should be chosen to ensure full combustion below the test item and not unduly increase the chance of occasional emergence of the test item from the flame envelope.

1.7 The test item should be prevented from falling into, and being quenched by, the fuel. Typically, a mesh tray may be placed beneath the test item; this should extend sufficiently to ensure that if the test item collapses or its contents fall out, such items will be held to remain exposed to the fire. The tray must not prevent complete engulfment of the test item by the fire and is typically sited about 50 mm below the surface of the fuel so that it retains its strength and does not affect the combustion of the fuel.

1.8 Any method used to restrain the test item in case of propulsion should not interfere with the heating of the item.

2. Test Conditions

2.1 The hearth should be large enough to allow at least 1m clearance on each side of the test item and designed to provide a volume of flame which completely engulfs the test item throughout the trial. The decision on whether to use a standard hearth or the mini-fuel fire test will depend upon the size of the item to be tested and the anticipated response.

2.2 The construction of the hearth and any associated walls should allow unrestricted debris throw and accurate measurement of blast overpressure to assist in determining the level of response.

2.3 Fuel – suitable liquid hydrocarbon fuels include JP-4, JP-5, JET A-1, AVCAT and commercial kerosene.

2.4 Where environmental concerns dictate, alternate fuel such as propane or natural gas may be used if testing verifies that the overall heat load to the test item matches what would be achieved from a liquid fuel fire at the established ramp and average temperature. For those items with exposed reactive surfaces (energetic materials, intumescent paints; not including packaging) the radiative conditions should match that of a liquid fuel fire.

2.5 The quantity of fuel required is a function of the size of the fuel basin and the characteristics of the item being tested. There should be sufficient fuel for the test item to be completely engulfed in the flames for at least 150% of the estimated time to reaction.

2.6 The average flame temperature should be at least 800°C as measured by all valid temperature measuring devices at the test item without any contribution from the burning ordnance. This temperature is determined by averaging the temperature from the time the flame reaches 550°C until all ordnance reactions are complete.

2.7 The wind speed within the hearth area must not be greater than 10 km/h to ensure that the test item is fully engulfed in the flames.

2.8 Other meteorological conditions, eg rain that might influence the test outcome should be avoided.

3. Test Facility

3.1 The choice of a test facility will be determined by the size and shape of the test item, the type of fuel to be used, the expected response and the required test data. The test facility needs to have a cleared area out to an appropriate distance for projection location and mapping

4. Test Instrumentation

4.1 Appropriate and adequate instrumentation should be utilised to provide sufficient data so that the severity of the response of the munition can be determined. Such instrumentation should include the following:

- Temperature profile history of heating rates at a minimum of 4 sites (or more as determined by the test plan) on the test item to give adequate flame profile with adequate sampling rates until the response of the munition is complete.
- Measurement of flame temperature as a function of time.
- Blast pressure measurements.
- Witness Plates.
- Fragment Velocity Screens.
- Still photography of the pre and post-test conditions.
- High speed video or cine coverage of the test item and the surrounding area.
- Measurement of sound via a microphone.
- Any other instrumentation as determined by the test plan and/or other requirement.

4.2 Measurement of thermal flux would be useful as it is a safety issue, for amongst others, the firefighters when a burning response is produced.

5. Observations and Records

5.1 The following minimum observations should be made and records kept:

- Test item identification (model, serial no etc.) including full details of any packaging.
- Type of energetic material and weight.
- The spatial orientation of the test item and method of suspension or mounting and/or restraint, height of bottom of test item above surface of fuel, distances from the test item to any protective wall or enclosure.
- Details of environmental pre-conditioning tests performed (if applicable).
- Temperature measuring device identification and locations.
- Description of test apparatus.
- Description of the instrumentation performance and of the methodology used to take the measurements.

- The type of fuel used for the test.
- Wind velocities and direction inside and outside the enclosure (if present) before the trial and any significant change in velocity/direction outside the enclosure (preferably well clear of the enclosure) during the trial.
- Record of the climatic conditions throughout the trial.
- Record of events versus time throughout the trial.
- Temperature-time history for each temperature measuring device.
- Pressure-time history.
- The time until flame temperature, as measured by any two of the temperature measuring devices, reaches 550°C shall be recorded.
- The average flame temperature.
- The identification and location of all debris, supported by a debris plot.

5.2 The following photographic records should be made:

- Still photographs of the test item before and after each trial, including the internal packing arrangement for packaged stores (ie with box lid removed). Include a dimensional reference.
- Still photographs of all significant debris resulting from the reaction of the test item (link with the debris plot). Include a dimensional reference.
- Colour cine film or video for the duration of each trial with time and audio correlation. Care should be taken in siting the camera(s) to ensure the best view of the test item and to minimise the likelihood of masking by smoke and flame. The cine or video should capture not only the reaction of the test item but also the ejection and spread of debris and firebrands around the test site.

SLOW HEATING - ISSUES TO BE CONSIDERED

1. Test Item Configuration

1.1 Normally, the test item will be unpackaged. Because the test item will be confined within a heating oven, observation and measurement of the level of response will be difficult and to add the additional complication of packaging might well prevent any sensible recording of the event.

1.2 There are exceptions, however. Small stores which are normally packaged throughout the life cycle up to the point of use such as Pyrotechnics, CADS/PADs, Small Arms and Cannon Ammunition, should be tested packaged. There is little point in conducting a Slow Heating test on a single bare 20 mm round of ammunition since it is the response of a full package that is of interest. Additionally, if there are strong reasons for undertaking the test on a larger munition in the packaged configuration, supported by the threat assessment, then a packaged test may be considered, but it may also be necessary to undertake an unpackaged test in order to obtain sufficient information to assess a level of response with any confidence.

1.3 For all-up rounds that contain more than one major energetic component (such as rocket motors and warheads), the energetic components may be tested either individually or as an all-up round.

1.4 The test item should be to the full production standard. Non explosive sections of the item need only be geometrically and thermally representative.

1.5 The use of simulants, dummy units or structures may affect heat flow patterns. If used, these should exhibit closely comparable behaviour to those of the actual items they replace.

1.6 Complex electronic units should be thermally simulated only if it can be demonstrated that there is no possibility of the test environment causing the unit to produce a spurious signal capable of initiating a firing circuit.

1.7 In slow heating tests, a substantial part of the explosive material may reach hazardous temperatures before ignition occurs. Therefore, subsequent events are often likely to be more violent than those that occur in fast heating tests.

1.8 The test fixtures should not interfere with the test stimulus (heating rate) imposed on the test item.

1.9 Any method of restraint to prevent propulsion should not affect the ability of the test item to rupture or fragment.

1.10 Extreme external conditions (e.g. wind, rain, temperature) that might influence the test outcome should be avoided.

1.11 The choice of test apparatus should be determined by the size and shape of the test item, the expected response and the required test data.

1.12 The test apparatus (such as the oven or the jacket) must be capable of providing the required thermal environment and increasing the temperature within the apparatus at the required rate throughout the anticipated temperature range. It should be designed to minimise hot spots and to ensure a uniform thermal environment for the item under test.

1.13 The test apparatus should be designed to minimise the possibility of secondary reactions such as those caused by exudate contacting the heating source. If exudation of the energetic filling is anticipated, consider ways of collecting the exudate to prevent such reactions.

2. Test Conditions

2.1 A rate of temperature rise of 3.3°C per hour should be used for the purpose of standardisation. This represents a worst case scenario and this heating rate should not be taken as the most likely slow heating

rate to be seen in service. For this reason, time to reaction may have little relevance to real life scenarios and, whilst it will be recorded, care should be taken in how it is subsequently used.

2.2 The test item should be at ambient temperature at the start of the test.

2.3 It is acceptable to raise the temperature of the test item more rapidly at the start of the test to reduce test time. The chamber temperature can be raised at up to 5.5°C per minute until a chamber temperature of 50°C is reached. At this point the heating must stop and the temperature maintained at 50°C for 8 hours or until the test item reaches thermal equilibrium at 50°C, whichever occurs first. Thermal modelling should be used to predict the length of time needed to achieve thermal equilibrium at 50°C.

2.4 The temperature should then be increased linearly at 3.3°C per hour until all reactions cease

3. Test Facility

3.1 The test is usually performed by placing the test item in a disposable oven and heating the item with circulating heated air.

3.2 The test facility should be capable of increasing the air temperature at the prescribed rate throughout the anticipated temperature range and maintaining a reasonably uniform temperature in the air around the test item. Some gradient in temperature between the input and exit air streams is to be expected, but this should not be greater than 5°C.

3.3 As an aid to achieving uniform temperatures, there should be an air space at least 200 mm wide on all sides of the item to allow for air circulation, and the oven should be insulated.

3.4 A minimum of four thermocouples should be used to ensure that the oven is uniformly heated and to monitor the surface temperature of the test item. Where it is possible to get access to the interior of the test item without altering the test item, interior temperatures should also be measured.

3.5 In general, there should be at least two thermocouples mounted on opposite surfaces of the test item, one each in the air space near the air inlet and exit, and one each in the air space on opposite sides of the round. The oven should be constructed so as to provide the least possible confinement for any reactions that occur, and it should have a window to permit video coverage.

4. Test Instrumentation

4.1 Appropriate and adequate instrumentation should be utilised to provide sufficient data so that the severity of response of the munition can be determined. Such instrumentation should include the following:

- Temperature as a function of time should be recorded at multiple positions on the surface of the test item and within the chamber. The thermocouple sampling rate should be at least once per minute.
- Blast pressure measurements.
- Witness Plates.
- Fragment Velocity Screens.
- Still photography of the pre and post-test conditions.
- High speed video or cine coverage of the test item (via a viewing window in the oven) and of the surrounding area.
- Measurement of sound via a microphone.
- Any other instrumentation as determined by the test plan and/or other requirement.

4.2 Measurement of thermal flux would be useful as it is a safety issue for, amongst others, the firefighters when a burning response is produced.

5. Observations and Records

5.1 The following minimum observations should be made and records kept:

- Test item identification (model, serial no etc.) including full details of any packaging.
- Type of energetic material and weight.
- The spatial orientation of the test item and method of suspension or mounting and/or restraint, distances from the test item/oven wall to any protective wall or enclosure.
- Details of environmental pre-conditioning tests performed (if applicable).
- Temperature measuring device identification and locations.
- Description of test apparatus, including the oven.
- The method used to heat the oven.
- Description of the instrumentation performance and of the methodology used to take the measurements.
- Record of the meteorological conditions throughout the trial.
- Record of events versus time throughout the trial.
- Temperature-time history for each temperature measuring device.
- Pressure-time history.
- The identification and location of all debris, supported by a debris plot.

5.2 The following photographic records should be made:

- Still photographs of the test item before and after each trial, including the internal packing arrangement for packaged stores (ie with box lid removed). Include a dimensional reference.
- Still photographs of the test set up and the heating oven, and the method used to mount the test item.
- Still photographs of all significant debris resulting from the reaction of the test item (link with the debris plot). Include a dimensional reference.
- Colour cine film or video for the duration of each trial with time and audio correlation. Care should be taken in siting the camera(s) to ensure the best view of the test item; for slow heating, a cine or video record should be taken through a viewing window in the oven. A second cine or video should capture not only the reaction of the test item but also the ejection and spread of debris and firebrands around the test site.

BULLET IMPACT - ISSUES TO BE CONSIDERED

1. Test Item Configuration

1.1 Normally, the test item will be unpackaged. Small stores which are normally packaged throughout the life cycle up to the point of use such as Pyrotechnics, CADS/PADs, Small Arms and Cannon Ammunition, should be tested packaged. There is little point in conducting a Bullet Impact test on a single bare 20 mm round of ammunition since it is the response of a full package that is of interest.

1.2 However, if there are strong reasons for undertaking the test on a larger munition in the packaged configuration, supported by the threat assessment, then a packaged test should be considered which may either be in addition to, or in place of, an unpackaged test.

1.3 For all-up rounds that contain more than one major energetic component (such as rocket motors and warheads), the energetic components may be tested either individually or as an all-up round.

1.4 The test item should be to the full production standard. Non explosive sections of the item need only be geometrically and thermally representative.

1.5 The use of simulants, dummy units or structures may affect heat flow patterns. If used, these should exhibit closely comparable behaviour to those of the actual items they replace.

1.6 Complex electronic units should be thermally simulated only if it can be demonstrated that there is no possibility of the test environment causing the unit to produce a spurious signal capable of initiating a firing circuit.

1.7 It is normal to mount the test item on a supporting stand in the horizontal axis but, if required, or if shown by the threat assessment to be appropriate, alternative configurations may be considered.

1.8 The test fixtures should not interfere with the test stimulus imposed on the test item or on its ability to rupture or fragment.

1.9 Any method of restraint (eg clamping or tethering) to prevent propulsion should not affect the ability of the test item to rupture or fragment.

2. Test Conditions

2.1 The line of fire should normally be at right angles to the longitudinal axis of the test item.

2.2 The exact range from gun to target should be determined by the test authorities, and will depend on accuracy and safety aspects.

2.3 The impact velocity should be $850 \pm 20 \text{ ms}^{-1}$. Sighting shots (usually 3) should be fired to confirm that the impact point will be hit and to calibrate the velocity.

2.4 Two points of aim should normally be selected. The first should be the largest explosive component (ie the main charge filling of the warhead or the propellant of the rocket motor) such that the bullet passes through the explosive. The second should be the most shock sensitive component, such as the rocket motor igniter or warhead booster, provided that it is credible that the bullet can penetrate sufficiently to achieve an impact. If this is to be combined for IM and Hazard Classification purposes, an additional test (for a total of three tests) is recommended.

2.5 It is important to conduct both tests since in terms of presented area, the likelihood of the largest explosive component being struck will be significantly greater whilst a strike on the most shock sensitive component may produce the most violent response. The aim point should be clearly marked on the test item and allowance made for the accuracy of the gun. Particular care is needed with packaged items to ensure that the desired aim point within the package is achieved.

2.6 The test item should be at ambient temperature at the start of the test unless the threat assessment shows that there are specific reasons for testing at a different temperature.

2.7 Extreme external conditions (e.g. wind, rain, temperature) that might influence the test outcome should be avoided.

2.8 If the impact of the bullet produces no reaction from the test item, it may be permissible to carry out a second bullet impact test on the same item. This will depend upon the amount of de-confinement caused by the entry (and, if appropriate, exit) of the bullet which, if significant, might invalidate the result of any subsequent test.

3. Test Facility

3.1 There are no special requirements for the test facility in relation to Bullet Impact.

4. Test Instrumentation

4.1 Appropriate and adequate instrumentation should be utilised to provide sufficient data so that the severity of response of the munition can be determined. Such instrumentation should include the following:

- Velocity sensors to measure bullet impact velocity.
- Blast pressure measurements.
- Witness Plates.
- Fragment Velocity Screens.
- Still photography of the pre and post-test conditions.
- High speed video or cine coverage of the test item and of the surrounding area. This should provide a view of the bullet striking the test item to confirm accuracy of aim.
- Measurement of sound via a microphone.
- Any other instrumentation as determined by the test plan and/or other requirement.

4.2 Measurement of thermal flux would be useful as it is a safety issue for, amongst others, the firefighters when a burning response is produced.

5. Observations and Records

5.1 The following minimum observations should be made and records kept:

- Test item identification (model, serial no etc.) including full details of any packaging.
- Type of energetic material and weight.
- The spatial orientation of the test item and method of suspension or mounting and/or restraint, distances from the test item to any protective wall or enclosure.
- Details of environmental pre-conditioning tests performed (if applicable).
- Description of the gun and ammunition used.
- Record of the aim point(s) selected.
- Record of where the bullet impacted the test item.
- Record of whether the bullet exited from the test item or remained within it.
- Description of the instrumentation performance and of the methodology used to take the measurements.

- Record of the meteorological conditions throughout the trial.
- Record of events versus time throughout the trial, from opening fire until all reactions from the test item have ceased. The times from impact of the bullet to initial reaction of the test item and, if the initial reaction is burning, until any subsequent more violent response, are of particular interest.
- Pressure-time history.
- The identification and location of all debris, supported by a debris plot.
- Indication of propulsion (from video, thrust measurement device or witness plate)

5.2 The following photographic records should be made:

- Still photographs of the test item before and after each trial, including the internal packing arrangement for packaged stores (ie with box lid removed). Include a dimensional reference.
- Still photographs of the test set up and the method used to mount the test item.
- Still photographs of all significant debris resulting from the reaction of the test item (link with the debris plot). Include a dimensional reference.
- Colour cine film or video for the duration of each trial with time and audio correlation. Care should be taken in siting the camera(s) to ensure the best view of the test item. A second cine or video should capture not only the reaction of the test item but also the ejection and spread of debris and firebrands around the test site.

FRAGMENT IMPACT - ISSUES TO BE CONSIDERED

1. Test Item Configuration

1.1 Normally, the test item will be unpackaged. Small stores which are normally packaged throughout the life cycle up to the point of use such as Pyrotechnics, CADS/PADs, Small Arms and Cannon Ammunition, should be tested packaged.

1.2 There is little point in conducting a Fragment Impact test on a single bare 20 mm round of ammunition since it is the response of a full package that is of interest. However, if there are strong reasons for undertaking the test on a larger munition in the packaged configuration, supported by the threat assessment, then a packaged test should be considered which may either be in addition to, or in place of, an unpackaged test.

1.3 For all-up rounds that contain more than one major energetic component (such as rocket motors and warheads), the energetic components may be tested either individually or as an all-up round.

1.4 The test item should be to the full production standard. Non explosive sections of the item need only be geometrically and thermally representative.

1.5 The use of simulants, dummy units or structures may affect heat flow patterns. If used, these should exhibit closely comparable behaviour to those of the actual items they replace.

1.6 Complex electronic units should be thermally simulated only if it can be demonstrated that there is no possibility of the test environment causing the unit to produce a spurious signal capable of initiating a firing circuit.

1.7 It is normal to mount the test item on a supporting stand in the horizontal axis but, if required, or if shown by the threat assessment to be appropriate, alternative configurations may be considered.

1.8 The test fixtures should not interfere with the test stimulus imposed on the test item or on its ability to rupture or fragment.

1.9 Any method of restraint (eg clamping or tethering) to prevent propulsion should not affect the ability of the test item to rupture or fragment.

2. Test Conditions

2.1 The line of fire should normally be at right angles to the longitudinal axis of the test item.

2.2 The exact range from fragment gun to target should be determined by the test authorities, and will depend on accuracy and safety aspects.

2.3 A single 18.6 g steel fragment, to the dimensions described in STANAG 4496 should be fired at the test item. STANAG 4496 Edition 1 calls up a standard test at a fragment velocity of 2530 ms^{-1} ; an alternative test at a lower velocity of 1830 ms^{-1} can be used where the threat assessment shows that there is an extremely low probability of the test munition experiencing a fragment at the higher velocity.

2.4 Two points of aim should normally be selected. The first should be the largest explosive component (ie the main charge filling of the warhead or the propellant of the rocket motor) such that the fragment passes through the explosive. The second should be the most shock sensitive component, such as the rocket motor igniter or warhead booster, provided that there is a credible probability that the fragment can penetrate sufficiently to achieve an impact; otherwise this second test can be omitted.

2.5 The aim point should be clearly marked on the test item and allowance made for the accuracy of the fragment gun. Particular care is needed with packaged items to ensure that the desired aim point within the package is achieved.

2.6 The test item should be at ambient temperature at the start of the test unless the THA shows that there are specific reasons for testing at a different temperature.

2.7 Extreme external conditions (e.g. wind, rain, temperature) that might influence the test outcome should be avoided.

3. Test Facility

3.1 There are no special requirements for the test facility in relation to Fragment Impact.

4. Test Instrumentation

4.1 Appropriate and adequate instrumentation should be utilised to provide sufficient data so that the severity of response of the munition can be determined. Such instrumentation should include the following:

- Velocity sensors to measure fragment impact velocity.
- Blast pressure measurements.
- Witness Plates.
- Fragment Velocity Screens.
- Still photography of the pre and post-test conditions.
- High speed video or cine coverage of the test item and of the surrounding area. This should provide a view of the fragment striking the test item to confirm accuracy of aim.
- Measurement of sound via a microphone.
- Any other instrumentation as determined by the test plan and/or other requirement.

4.2 Measurement of thermal flux would be useful as it is a safety issue for, amongst others, the firefighters when a burning response is produced.

5. Observations and Records

5.1 The following minimum observations should made and records kept:

- Test item identification (model, serial no etc.) including full details of any packaging.
- Type of energetic material and weight.
- The spatial orientation of the test item and method of suspension or mounting and/or restraint, distances from the test item to any protective wall or enclosure.
- Details of environmental pre-conditioning tests performed (if applicable).
- Description of the fragment gun and of the fragment including weight, dimensions and material.
- Record of the aim point(s) selected.
- Record of where the fragment impacted the test item.
- Record of whether the fragment exited from the test item or remained within it (where the case of the test item remains intact.)
- Description of the instrumentation performance and of the methodology used to take the measurements.
- Record of the meteorological conditions throughout the trial.
- Record of events versus time throughout the trial.
- Pressure-time history.
- The identification and location of all debris, supported by a debris plot.
- Indication of propulsion (from video, thrust measurement device or witness plate)

5.2 The following photographic records should be made:

- Still photographs of the test item before and after each trial, including the internal packing arrangement for packaged stores (ie with box lid removed). Include a dimensional reference.
- Still photographs of the test set up and the method used to mount the test item.
- Still photographs of all significant debris resulting from the reaction of the test item (link with the debris plot). Include a dimensional reference.
- Colour cine film or video for the duration of each trial with time and audio correlation. Care should be taken in siting the camera(s) to ensure the best view of the test item. A second cine or video should capture not only the reaction of the test item but also the ejection and spread of debris and firebrands around the test site.

SYMPATHETIC REACTION - ISSUES TO BE CONSIDERED

1. Test Item Configuration

1.1 The sympathetic reaction test is designed to assess the propagation of reaction of a munition in the logistic configuration and will therefore require a packaged donor munition and a number of packaged acceptor munitions.

1.2 In order to provide a representative logistic configuration (eg pallet load) with representative confinement, additional inert packaged munitions (or containers filled with sand to replicate the level of confinement) may also be used.

1.3 The number of acceptors and inert stores will depend on the logistic configuration. Normally at least 3 acceptors should be used, including one positioned diagonally so that the test replicates the focussing effect which can result in greater fragment energy in a diagonal direction. If the test is to be a combined IM and Hazard Classification tests, the total volume of the packaged test items should not be less than 0.15m³ in order to comply with UN Hazard testing requirement.

1.4 For small stores, such as Pyrotechnics, CADs and PADs and Small Arms Ammunition, the purpose of the test is to determine package to package propagation. If it is assessed as likely that all the effects will be contained within the donor package, then the test can be conducted using a single package. If this shows that effects external to the package do occur, then the test will have to be repeated using donor and acceptor packages.

1.5 There may be circumstances in which it is also necessary to test the munitions unpackaged, if the threat assessment requires it, for example for stores which are stacked unpackaged and are likely to be exposed to threats which might cause one or more stores to detonate, or for stores which are mounted in close proximity on an aircraft pylon or in a ship's magazine.

1.6 For all-up rounds that contain more than one major energetic component (such as rocket motors and warheads), the energetic components may be tested individually. However, because of the interaction between components, a test using all-up rounds will always be required.

1.7 The test items should be to the full production standard. Non explosive sections of the items need only be geometrically and thermally representative.

1.8 The use of simulants, dummy units or structures may affect heat flow patterns. If used, these should exhibit closely comparable behaviour to those of the actual items they replace.

1.9 Complex electronic units should be thermally simulated only if it can be demonstrated that there is no possibility of the test environment causing the unit to produce a spurious signal capable of initiating a firing circuit.

1.10 Acceptor stores should be marked (eg by painting each a different colour) to assist with debris identification.

2. Test Conditions

2.1 For HE munitions, the donor should be initiated in design mode to achieve full detonation. This may be done using plastic explosive to initiate the booster or using electrical means to initiate a detonator. It is essential that full detonation is achieved.

2.2 For rocket motors, the normal method of initiating the donor is to attack the propellant through the motor case using a shaped charge warhead at an appropriate stand off. For smaller stores which are not designed to detonate, the donor store should be initiated in design mode.

2.3 The test items should be at ambient temperature at the start of the test unless the threat assessment shows that there are specific reasons for testing at a different temperature.

2.4 Extreme external conditions (e.g. wind, rain, temperature) that might influence the test outcome should be avoided.

3. Test Facility

3.1 The test facility needs to have a cleared area out to an appropriate distance for projection location and mapping.

4. Test Instrumentation

4.1 Appropriate and adequate instrumentation should be utilised to provide sufficient data so that the severity of response of the munition can be determined. Such instrumentation should include the following:

- Velocity sensors to measure fragment impact velocity.
- Blast pressure measurements. It is useful to conduct a preliminary test to record the blast overpressures generated by the donor alone; this will also provide confidence that the method of initiation does achieve a full detonation.
- Witness Plates.
- Fragment Velocity Screens.
- Still photography of the pre and post-test conditions.
- High speed video or cine coverage of the test item and of the surrounding area. This should provide a view of the fragment striking the test item to confirm accuracy of aim.
- Measurement of sound via a microphone.
- Any other instrumentation as determined by the test plan and/or other requirement.

4.2 Measurement of thermal flux would be useful as it is a safety issue for, amongst others, the firefighters when a burning response is produced.

5. Observations and Records

5.1 The following minimum observations should made and records kept:

- Test item identification (model, serial no etc. for donor and all acceptors) including full details of the packaging.
- Type of energetic material and weight.
- The spatial orientation of the test items and method of suspension or mounting and/or restraint, distances from the test item to any protective wall or enclosure.
- Details of environmental pre-conditioning tests performed (if applicable).
- Confirmation that the donor detonated as required.
- Description of the instrumentation performance and of the methodology used to take the measurements.
- Record of the meteorological conditions throughout the trial.
- Record of events versus time throughout the trial.
- Pressure-time history.
- The identification and location of all debris, supported by a debris plot. It is important to distinguish between donor and individual acceptors.

5.2 The following photographic records should be made:

- Still photographs of the test items before and after each trial, including the internal packing arrangement for packaged stores (ie with box lid removed). Include a dimensional reference.
- Still photographs of the test set up and the method used to mount the test item.
- Still photographs of all significant debris resulting from the reaction of the test item (link with the debris plot). Include a dimensional reference.
- Colour cine film or video for the duration of each trial with time and audio correlation. Care should be taken in siting the camera(s) to ensure the best view of the test item. A second cine or video should capture not only the reaction of the test item but also the ejection and spread of debris and firebrands around the test site.

SHAPED CHARGE JET IMPACT - ISSUES TO BE CONSIDERED

1. Limitations

1.1 The test is most appropriate for systems containing energetic materials having a detonation failure diameter significantly larger than the jet diameter. Systems containing energetic materials with small failure diameters, including most current warheads, will normally fail this test. This should be considered this when determining whether or not to conduct the test.

1.2 If other data indicate that the test item is very unlikely to pass the test, there is little point in wasting resources by conducting the test just to confirm failure.

1.3 The test may also be unnecessary if it can be reliably shown that the detonation failure diameter of the energetic material is larger than the diameter of the munition (so that a detonation cannot be sustained in the munition), and if the threat assessment indicates that reactions less severe than Type I or Type II are not a concern. In order to make this judgement, determine the detonation failure diameter with the energetic material confined as it would be in the real munition.

1.4 Make such a judgement only for very large and expensive test items, and support such a determination by data on the energetic material that is validated by knowledgeable national authorities. Material that passes this test is not necessarily acceptable in a tactical situation. Other tests may be required.

1.5 Where a shaped charge jet is used to initiate a donor munition in a Sympathetic Reaction test, the resulting response of the donor can be used as evidence of the reaction to Shaped Charge Jet Impact and there is no need to perform a separate test.

2. Test Item Configuration

2.1 The test may be carried out packaged or unpackaged (or both) as determined by the threat assessment. Small stores which are normally packaged throughout the life cycle up to the point of use, such as Pyrotechnics, CADS/PADs, Small Arms and Cannon Ammunition, should be tested packaged. In such cases, where it is assessed that the input energy of the Shaped Charge Warhead will significantly exceed the output energy from the test item, there may be little point in conducting the test.

2.2 For all-up rounds that contain more than one major energetic component (such as rocket motors and warheads), the energetic components may be tested either individually or as an all-up round.

2.3 The test item should be to the full production standard. Non explosive sections of the item need only be geometrically and thermally representative.

2.4 The use of simulants, dummy units or structures may affect heat flow patterns. If used, these should exhibit closely comparable behaviour to those of the actual items they replace.

2.5 Complex electronic units should be thermally simulated only if it can be demonstrated that there is no possibility of the test environment causing the unit to produce a spurious signal capable of initiating a firing circuit.

2.6 It is normal to mount the test item on a supporting stand in the horizontal axis but, if required, or if shown by the THA to be appropriate, alternative configurations may be considered.

2.7 The test fixtures should not interfere with the test stimulus imposed on the test item or on its ability to rupture or fragment.

2.8 Any method of restraint (eg clamping or tethering) to prevent propulsion should not affect the ability of the test item to rupture or fragment.

3. Test Conditions

3.1 STANAG 4526 Ed 2 includes both a standard test and a tailored test. For the standard test, the test item is subjected to the jet from a shaped charge representing the 50 mm Rockeye warhead, or an equivalent having a similar V^2d value. For the tailored test, the shaped charge is selected according to the threat assessment. The STANAG gives guidance on typical V^2d values associated with particular threat types and the requirements for characterisation of the jet if the standard 50 mm Rockeye is not used.

3.2 The aim is to attack the main energetic material filling of the munition and the line of fire should be chosen to give the longest possible path length in the energetic material. Unlike bullet and fragment impact tests, there is no point in attacking small components such as the igniter.

3.3 The shaped charge should be placed at a realistic stand off from the munition or its packaging/shielding as determined by the threat assessment. The stand off influences the V^2d delivered by a shaped charge and it is important to specify the stand off as part of the jet characterisation.

3.4 The test item should be at ambient temperature at the start of the test unless the threat assessment shows that there are specific reasons for testing at a different temperature.

3.5 Extreme external conditions (e.g. wind, rain, temperature) that might influence the test outcome should be avoided.

4. Test Facility

4.1 There are no special requirements for the test facility in relation to Shaped Charge Jet Impact.

5. Test Instrumentation

5.1 Appropriate and adequate instrumentation should be utilised to provide sufficient data so that the severity of response of the munition can be determined. The passing criterion is a Type III reaction and higher order reactions are possible. Thus the instrumentation should be selected noting that Types I to III responses are likely. Such instrumentation should include the following:

- Velocity sensors to measure fragment impact velocity.
- Blast pressure measurements.
- Witness Plates.
- Fragment Velocity Screens.
- Still photography of the pre and post-test conditions.
- High speed video or cine coverage of the test item and of the surrounding area.
- Measurement of sound via a microphone.
- Any other instrumentation as determined by the test plan and/or other requirement.

5.2 Measurement of thermal flux would be useful as it is a safety issue for, amongst others, the firefighters when a burning response is produced.

6. Observations and Records

6.1 The following minimum observations should be made and records kept:

- Test item identification (model, serial no etc.) including full details of any packaging.
- Type of energetic material and weight.

- The spatial orientation of the test item and method of suspension or mounting and/or restraint, distances from the test item to any protective wall or enclosure.
- Details of environmental pre-conditioning tests performed (if applicable).
- A full characterisation of the shaped charge jet.
- Record of the aim point selected and the angle of the jet to the munition.
- Description of the instrumentation performance and of the methodology used to take the measurements.
- Record of the meteorological conditions throughout the trial.
- Record of events versus time throughout the trial.
- Pressure-time history.
- The identification and location of all debris, supported by a debris plot.
- Indication of propulsion (from video, thrust measurement device or witness plate)

6.2 The following photographic records should be made:

- Still photographs of the test item before and after each trial, including the internal packing arrangement for packaged stores (ie with box lid removed). Include a dimensional reference.
- Still photographs of the test set up and the method used to mount the test item, including the positioning of the shaped charge.
- Still photographs of all significant debris resulting from the reaction of the test item (link with the debris plot). Include a dimensional reference.
- Colour cine film or video for the duration of each trial with time and audio correlation. Care should be taken in siting the camera(s) to ensure the best view of the test item. A second cine or video should capture not only the reaction of the test item but also the ejection and spread of debris and firebrands around the test site.

INTERPRETATION OF MUNITION TYPES OF RESPONSES

To assess a munition response type it is vital to record as much relevant data as possible. Blast and fragmentation are two key elements:

- Blast overpressure measurements at 5, 10 and 15 m will give an indication of the level of response although there is no absolute scale; the explosion of a large munition with a high Net Explosive Quantity (NEQ) will give considerably higher blast overpressures than explosion of a small munition with a low NEQ.
- The degree of case fragmentation, fragment size and distance thrown are another measure used to judge reaction type. Detonation reactions typically shatter the munition case into small fragments and project debris over considerable distance, with the entire energetic filling being consumed in the reaction. As the violence of reaction reduces through explosion to deflagration, so the size of fragments will increase, the distance thrown reduces and greater amounts of unreacted filling will remain, whilst for a burning reaction, there will be no fragmentation or debris thrown beyond 15 meters with an energy above 20 J. It is therefore important to map the debris throw from each test, identifying each item, its size and weight, and the distance it has been thrown, supported by photographic evidence of the debris. It is also very important to clear the test range of debris from a previous test before the next test is started, otherwise the test site will be contaminated with old debris which will confuse the identification and mapping process.
- Other means of measuring violence of response include the use of witness plates to record blast and fragment output from an explosion or detonation and velocity screens to measure fragment velocity and size. Ionisation probes placed along the body of the test item to measure the speed of the reaction and distinguish between detonation and explosion is also a possibility. The video record of the test is a vital piece of evidence and can often provide a good indication of the violence of reaction which, when combined with other data, enables the reaction type to be assessed with some confidence.

This Annex lists typical munition behaviour and resulting effects on the environment corresponding to the NATO response descriptors (i.e. munition types of response).

TYPES OF RESPONSE

These IM Response Descriptors are designed to be used by Subject Matter Experts (SMEs) to determine the IM response type of munitions tested in accordance with STANAG 4439 and require the SME to use their experience and engineering judgment. For example, munitions vary greatly in size, type, packaging and energetic materials; these differences need to be taken into account. In addition, the scattering of debris caused by the mechanical momentum transfer imparted by the test procedure and not the reaction of the test item can be factored out of the evidence used to assign an IM response level. For a reaction to be judged a particular type, the Primary Evidence for that type would need to be present. The entire (both primary and secondary) body of evidence must be weighed carefully and used in its entirety by experienced SMEs to assess the reaction. The secondary evidence provides other indicators that may be present.

Detonation (Type I).

The most violent type of munition reaction where the energetic material is consumed in a supersonic decomposition.

Primary evidence of a Type I reaction is the observation or measurement of a shock wave with the magnitude and timescale of a purposely detonated calibration test or calculated value and the rapid plastic deformation of the metal casing contacting the energetic material with extensive high shear rate fragmentation.

Secondary evidence may include the perforation, fragmentation and-or plastic deformation of a witness plate and ground craters of a size corresponding to the amount of energetic material in the munition.

Partial Detonation (Type II).

The second most violent type of munition reaction where some of the energetic material is consumed in a supersonic decomposition.

Primary evidence of a Type II reaction is the observation or measurement of a shock wave with magnitude less than that of a purposely detonated calibration test or calculated value and the rapid plastic deformation of some, but not all, of the metal casing contacting the energetic material with extensive high shear rate fragmentation.

Secondary evidence may include scattered burned or unburned energetic material; the perforation, fragmentation and-or plastic deformation of a witness plate; and ground craters.

Explosion (Type III).

The third most violent type of munition reaction with sub-sonic decomposition of energetic material and extensive fragmentation.

Primary evidence of a Type III reaction is the rapid combustion of some or all of the energetic material once the munition reaction starts and the extensive fracture of metal casings with no evidence of high shear deformation resulting in larger and fewer fragments than observed from purposely detonated calibration tests.

Secondary evidence may include significant long-distance scattering of burning or unburned energetic material; witness plate damage; the observation or measurement of overpressure throughout the test arena with a peak magnitude significantly less than and significantly longer duration than that of a purposely detonated calibration test; and ground craters.

Deflagration (Type IV).

The fourth most violent type of munition reaction with ignition and burning of confined energetic materials which leads to a less violent pressure release.

Primary evidence of a Type IV reaction is the combustion of some or all of the energetic material and the rupture of casings resulting in a few large pieces that might include enclosures and attachments. At least one piece (e.g., casing, packaging or energetic material) travels (or would have been capable of travelling) beyond 15m and with an energy level greater than 20J based on

the distance versus mass relationships in figure B-1. A reaction is also classified as Type IV if there is no primary evidence of a more severe reaction and there is evidence of thrust capable of propelling the munition beyond 15m.

Secondary evidence may include a longer reaction time than would be expected in a Type III reaction; significant scattered burning or unburned energetic material, generally beyond 15m; and some evidence of pressure in the test arena which may vary in time or space.

Burn (Type V).

The fifth most violent type of munition reaction where the energetic material ignites and burns non-propulsively.

Primary evidence of a Type V reaction is the low pressure burn of some or all of the energetic material. The casing may rupture resulting in a few large pieces that might include enclosures and attachments. No piece (e.g., casing, packaging or energetic material) travels (or would have been capable of travelling) beyond 15m and with an energy level greater than 20J based on the distance versus mass relationships in figure B-1. There is no evidence of thrust capable of propelling the munition beyond 15m. A small amount of burning or unburned energetic material relative to the total amount in the munition may be scattered, generally within 15m but no more than 30m.

Secondary evidence may include some evidence of insignificant pressure in the test arena and for a rocket motor a significantly longer reaction time than if initiated in its design mode.

No Reaction (Type VI).

The least violent type of munition response where any reaction is self-extinguished immediately upon removal of the external stimulus.

Primary evidence of a Type VI reaction is no reaction of the energetic material without a continued external stimulus; the recovery of all or most of the energetic material with no indication of sustained combustion; and no fragmentation of the casing or packaging greater than from a comparable inert test item.

Secondary evidence – none.

Figure B-1. Relationship of Projection Kinetic Energy and Hazard Division (20 J)

Mass (g)	Projection distance (m)	
	20 J	8 J
25	83.6	46.8
50	58.4	28.7
75	44.4	20.6
100	35.6	16.2
125	29.8	13.3
150	25.6	11.4
175	22.43	10
200	20	8.8
300	13.9	6.3
400	10.9	4.9
500	8.9	4.1

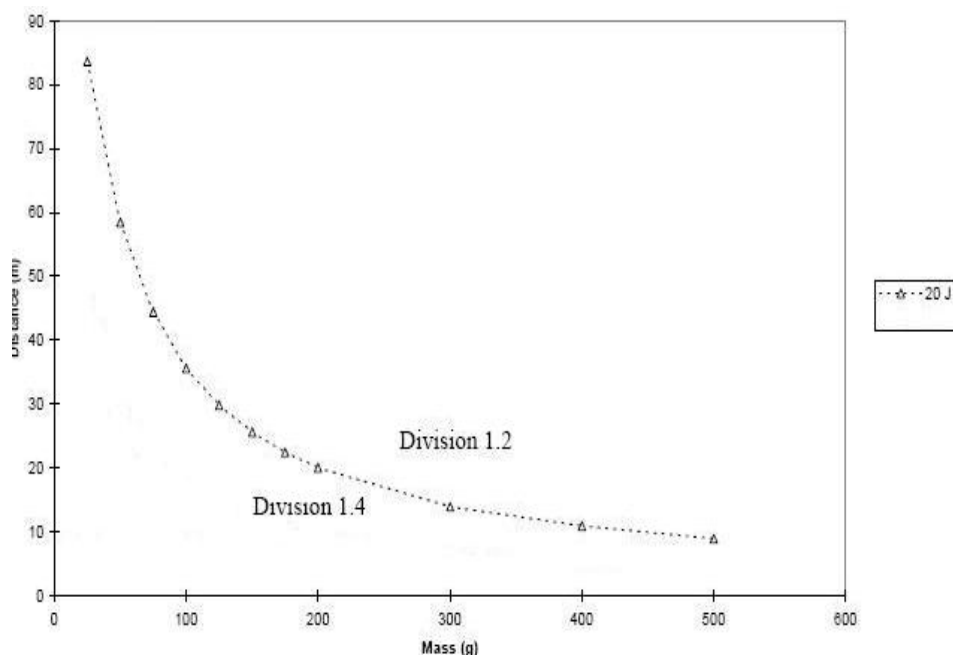

Response Level	Energetic Materials (EM)	Case	Blast	Fragment or EM projection	Other
Type I (detonation)	Prompt consumption of all EM once the reaction starts	(P) Rapid plastic deformation of the metal casing contacting the EM with extensive high shear rate fragmentation	(P) Shock wave with magnitude & timescale = to a calculated value or measured value from a calibration test	Perforation, fragmentation and/or plastic deformation of witness plates	Ground craters of a size corresponding to the amount of EM in the munition
Type II (partial detonation)		(P) Rapid plastic deformation of some, but not all, of the metal casing contacting the EM with extensive high shear rate fragmentation	(P) Shock wave with magnitude & timescale < than that of a calculated value or measured value from a calibration test Damage to neighbouring structures	Perforation, plastic deformation and/or fragmentation of adjacent metal plates. Scattered burned or unburned EM.	Ground craters of a size corresponding to the amount of EM that detonated.
Type III (explosion)	(P) Rapid combustion of some or all of the EM once the munition reaction starts	(P) Extensive fracture of metal casings with no evidence of high shear rate fragmentation resulting in larger and fewer fragments than observed from purposely detonated calibration tests	Observation or measurement of a pressure wave throughout the test arena with peak magnitude << than and significantly longer duration than that of a measured value from a calibration test	Witness plate damage. Significant long distance scattering of burning or unburned EM.	Ground craters.
Type IV (deflagration)	(P) Combustion of some or all of the EM	(P) Rupture of casings resulting in a few large pieces that might include enclosures or attachments.	Some evidence of pressure in the test arena which may vary in time or space.	(P) At least one piece (casing, enclosure or attachment) travels beyond 15m with an energy level > 20J based on the distance/mass relationship used for HC¹. Significant scattered burning or unburned EM, generally beyond 15 m.	(P) There is no primary evidence of a more severe reaction and there is evidence of thrust capable of propelling the munition beyond 15m. Longer reaction time than would be expected in a Type III reaction.
Type V (burn)	(P) Low pressure burn of some or all of the EM	(P) The casing may rupture resulting in a few large pieces that might include enclosures or attachments.	Some evidence of insignificant pressure in the test arena.	(P) No item (casing, enclosure, attachment or EM) travels beyond 15m with an energy level > 20J based on the distance/mass relationship used for HC¹. (P) A small amount of burning or unburned EM relative to the total amount in the munition may be scattered, generally within 15m but no further than 30m.	(P) No evidence of thrust capable of propelling the munition beyond 15m. For a rocket motor a significantly longer reaction time than if initiated in its design mode.
Type VI (no reaction)	(P) No reaction of the EM without a continued external stimulus. (P) Recovery of all or most of the unreacted EM with no indication of a sustained combustion.	(P) No fragmentation of the casing or packaging greater than that from a comparable inert test item.	None	None	None

Primary evidence (P), shown in **Bold** text, would almost always be observed and would be definitive of the reaction type.

Secondary evidence could be observed, but its lack would not preclude that reaction type.

Note: (1) Fragment energy relationship shown in the Figure I-1

PRESENTING THE IM SIGNATURE

1. The IM signature is a representation of the IM level of the munition, i.e. the response level of the munition to the IM threats.
2. The IM signature should report the following information:
 - Munition assessed and configuration
 - The threats: Slow Heating (SH), Fast Heating (FH), Bullet Impact (BI), Fragment Impact (FI), Sympathetic Reaction (SR), Shaped Charge Jet Impact (SCJI).
 - The range of validity of the assessment (specific threat, baseline range, full range ...)
 - The response type for each threat: Type I response (Detonation) (I), Type II response (Partial Detonation) (II), Type III response (Explosion) (III), Type IV response (Deflagration) (IV), Type V response (Burning) (V), No reaction (NR).
 - The assessment methodology for each response type (Analysis and/or Full Scale Test)
 - The fulfilment with the IM requirements
3. Example 1: in the following IM signature, the symbol (O) represents the assessed response in a particular configuration (configuration 1). A simple colour coding system is included to readily identify a pass (white area) or a failure (shaded area). To be compliant with the IM requirements defined in STANAG 4439, all the symbols should be positioned in the white area.

Table 3 - IM Signature example 1

Munition configuration 1

	FH	SH	BI	FI	SR	SCJI
No Reaction			O			
Type V	O	O				
Type IV				O		
Type III						O
Type II						
Type I						

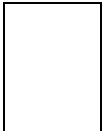
 IM requirement fulfilled

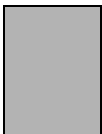
 IM requirement not fulfilled

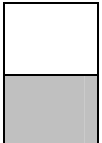
 Not Assessed

3. Example 2: in the following IM signatures, a more detailed traffic light colour coding system is used to reflect fulfillment or how far from fulfillment the munition is. The colour coding system is presented in Table 2. To be compliant with IM requirement defined in STANAG 4439, all the boxes should be coloured light green.

Table 2 - IM Signature Colour Coding

Colour Coding	IM Compliance	
Green	IM requirement fulfilled.	Pass (P)
Yellow	IM requirement not fulfilled. One response level difference between the assessed response level and the IM requirement	Fail (F)
Red	IM requirement not fulfilled. Two and plus response levels difference between the assessed response level and the IM requirement	
White	Not Assessed (N/A)	Not Assessed

Examples of IM signature integrating both a colour code and a response type code are presented in Table 3.

Table 3- IM Signature: Example 2

		FH	SH	BI	FI	SR	SCJI
Configuration 1		V	V	NR	IV	N/A	III
Configuration 2		III	IV	IV	N/A	N/A	I
Configuration 3	Warhead	(I)	N/A	NR	V Main Charge III Booster	P	F
	Propulsion Unit	IV	V	V 0.50 AP IV 7.62 Ball	N/A	N/A	(P)
	Full-up Round	(I)	V	IV	III	P	F

() – Analysis

4. The IM compliance signature corresponding to the worst credible life cycle configuration identified for each considered threat, the relevant configurations and threats have to be clearly reported.

In the following example of IM compliance signature for the munition X, the symbols **O**, **□**, **▽** represent the assessed response in particular configurations (respectively bare configuration, logistical package unfuzed configuration and logistical packaged fuzed configuration).

To be compliant with the IM requirements defined in STANAG 4439, all the symbols should be positioned in the white area.

Table 4 - IM Compliance Signature Example

Munition X: IM compliance signature

	FH	SH	BI	FI	SR	SCJI
No Reaction			O			
Type V	O	□				
Type IV				▽		
Type III						O
Type II					▽	
Type I						

IM ASSESSMENT REPORT

At a minimum, the following elements shall be included in the IM Assessment Report.

Executive summary

The executive summary is a summary of the information able to be released to nations requesting information related to the IM level of the munition. At least the following information should be reported:

- Information related to the munition energetic materials, design and packaging.
- IM signature(s) for the different configurations.
- IM compliance signature.
- The assessed threat range validity.

Munition system information

- Munition specific reference
- Intended operational use.
- Munition design information including design trade studies affecting IM.
- Energetic components. All energetic components should be specifically addressed.
- Hazard Classification for transport and/or storage. Identify whether the Hazard Classification is Interim or Final.
- Munition Safety information in accordance with STANAG 4297.

Assessed configuration(s)

- Tactical Configuration.
- Logistics Configuration(s).
- Packaging Design.
- Palletization Layout.

Munition threat analysis

- Definition of the service environment including the manufacture-to-target or disposal sequence for the munition (Life-cycle profile).
- Description of the significant threats to the weapon system during its “cradle to grave” life cycle. Include both hostile and “friendly” threats with a special emphasis on the IM threats. Describe how the analysis was conducted (include references) and present a summary table of the results.

Supporting evidence

- **Modelling results**

Modelling can be used where proven capabilities exist, properly validated against experiment.

This statement also lends support to the idea that small scale testing and modelling data should be considered complementary to test data or, in some cases replace them, and should, in fact, be the primary means of assessment, with full-scale tests used to validate the modelling results. Of course, this methodology depends on the existence of proven models. But the methodology should be in place to use the current modelling capabilities as they improve and evolve over time. It should be noted also that the usefulness of complementary information will always depend on its validity, and whether it is interpreted in the proper context. Only then can it serve to increase confidence.

- **Tests results**

Tests results may include laboratory testing, small scale testing, sub scale testing, full scale testing, components testing, and energetic material(s) testing in accordance with STANAG 4170 and AOP-7. Concerning the IM tests, the following information should be thorough enough to permit a clear scoring of the test results.

- Test report(s)

- Setup information/item configuration
 - Photographs and videos of set up and results.
 - Description of information and any quantitative data recorded (e.g., pressure, temperature).
 - Debris maps.
 - Describe the results of IM tests on components and all-up-rounds.
 - Describe the type of reaction which occurred in accordance with definitions of reaction and provide references.
- **Historical data including results on munition variants and read-across results from similar munition**

IM Signature(s)

See Annex J for more information

IM DESIGN TECHNIQUES

The most effective method for achieving successful Insensitive Munition (IM) design is to use a system approach. The three key elements in the IM system approach are:

- The choice of the energetic materials (EMs)
- The mitigation technologies and design tradeoffs integrated in the design of the case and more generally in the inert parts of the munition.
- The mitigation technologies and design tradeoffs integrated in the design of the packaging

These three key elements will be reviewed in the following sections. The particular case of fuzes is presented in appendix L-1.

1. The Energetic Material Selection

Normally, the first step is to determine the EMs that are to be used. The decision on which EM is suitable for a specific application is governed by many factors that each needs to be tradeoff to provide the most practical solution:

- Cost
- Performance
- Producibility (infrastructure availability, supply decisions and off-sets for ingredients...)
- Technology maturity (development status, existence of specifications, whether qualified or not...)
- Health & Safety (Environmental considerations, toxicity...)
- Sensitiveness to shock, heat and impact
- Ageing

Since it is the energetic materials that create the hazard, it is necessary to take into account the characteristics of each energetic material as it determines its propensity for giving benign responses to the stimuli defined. Material qualification in accordance with the requirements of STANAG 4170 and AOP-7 will provide some of the necessary data.

When selecting a suitable EM for an IM application, it is highly desirable that it possesses inherent low vulnerability (i.e. reduced response) to the IM stimuli (shock and thermal). The factors that contribute to the EM response are discussed below.

1.1 Response of the EM to Shock Stimuli

The basic physical phenomena underlying the initiation of heterogeneous high explosives due to shock waves are finite rate chemical reactions involved in the conversion of solid explosive to gas reaction products. These reactions are initiated at localized "hot spots" or more generally at localized energy sources. Void collapse, viscoplastic effects, multiphase reactions, shear banding, adiabatic gas compression, friction and shock reflections from internal imperfections are mechanisms that have been proposed as energy sources. Because the relative importance of each of these mechanisms is still subject to considerable conjecture, a simple ordering of materials by shock sensitivity is not possible. Indeed, the shock required to initiate an EM charge is dependent on:

- The microstructure, which determines the nature of the hotspots.
- The chemistry, which determines the response.
- The macrostructure, which determines the propagation of the response.

Microstructural parameters that can influence the response to shock include particle size, particle distribution, particle shape, intragranular porosity/voids and extragranular porosity/voids. Macrostructural parameters that can influence the response to shock include density, intrinsic sensitivity, total solids content, mechanical properties, voids and cracks.

EMs should, wherever possible, have the following characteristics:

- High resistance to damage
- Non friable
- Toughness
 - High elongation with plastic failures (especially at low temperature and high loading rates)
 - Low glass transition temperature ingredients
- Good mechanical properties with low elastic modulus binders
- High specific heats and heats of fusion polymers to encourage hot spot quench
- Low sensitivity components
- Optimum particle distributions for binder wetting and particle to particle bond strength
- Minimum porosity
- Reduced total solids level

1.2 Response of the EM to Thermal Stimuli

Cook-off involves chemistry and physics and covers a diverse range of subjects such as combustion, material properties and thermal explosion theory. Two phases have to be distinguished:

- The pre-ignition phase where the combined thermal, chemical and mechanical behaviour of each decomposing energetic material has to be determined. To predict the evolution of the energetic material state during the thermal aggression, the effects of thermal expansion, mechanical loading, phase transformation, and chemical decomposition have to be captured. This includes elasticity, volumetric and deviatoric creep, thermal expansion, chemical decomposition, porosity and phase change. In this phase, the mechanical response of the case is quasi-static.
- The post-ignition phase where the mechanical response of the case becomes dynamic. The dynamic response of the energetic material is anticipated to be strain rate, stress rate, and temperature dependent. Combustion is heavily dependent on thermal damage. Specifically increased surface area and pressure have an important role to play.

The key factor in determining the final violence of reaction is the order of magnitude of the pressure increase, i.e. the pressurization rate. This pressure increase will be controlled by the dynamic interaction between:

- The external and internal surface area available for burn (damage influence).
- The burn rate (flame spread rate influence).
- The venting to the outside (confinement influence).

EM properties that can influence the response to thermal stimuli include:

- Thermal properties that control the heat flow, the ignition and growth of reactions. These include the thermal conductivity and the ignition temperature.
- Mechanical properties that determine the ability of the energetic material to flow into gaps to block vent path or to sustain internal pressures and deflagration behaviour.

Some recommendations regarding the EM to be used are:

To prevent damage by:

- Decreasing subsurface porosity produced
- Minimizing cracks and voids formation
- Minimizing molten phase

To prevent high flame spread rate by:

- Resisting or reducing the propagation of flames in the early stages of the growth of the reaction
- Limiting void growth if ignition occurs in the solid phase (i.e. Melting Temperature < Critical Temperature)
- Increasing pressure deflagration limit
- Decreasing thermal conductivity

2. The Munition Design

2.1 Hardware Material Selection and Design

When designing a munition, mitigation technologies and design tradeoffs can be integrated into the design of the case to reduce the level of reaction. These technologies are divided into three types:

1. Barrier technologies aiming at preventing or/and mitigating the effects of the IM stimuli.
2. Venting/de-confining technologies aiming at releasing/preventing the catastrophic build-up of pressure due to the reaction of the energetic material if reaction occurs.
The critical parameters for designing a suitable venting system are the rate of pressurization and the rate of pressure release through venting. Venting can be achieved either through the natural disruption of the case (this is for example the case for lightly confined systems that are usually able to break open once the EM ignites) or the utilization of mitigation techniques (this is for example required for heavily confined casing).
 - Natural venting. Tradeoffs need to be made between performance and IM reaction level for the considered case thickness and strength. Table L-1 compares IM related advantages and disadvantages of various natural venting technical solutions.

Table L-1: Comparison of Natural Venting Technological Solutions

	Advantages	Disadvantages
Thick vs. Thin case	Higher shock attenuation Higher protection against impact Lower temperature increase vs. time	Smaller venting after perforation Higher pressure build up Lower critical diameter Higher weight
High strength vs. Low strength case	Higher performance Lower pressure build up (if brittle)	Higher weight
Metallic vs. Non metallic case	Higher protection against impact Lower cost	Higher pressure build up

- Mitigation Techniques. Venting systems can be divided into two basic types, active and passive:
 - i. Active systems rely on the initiation of an energetic device to cut open the case or create sufficient weakness to allow a relatively benign separation at a certain pressure.
 - ii. Passive systems rely on chemical or physical changes within specific materials to allow the creation of vent holes or the benign expulsion of end plates/closures.
3. In some cases the same technology can both act as a barrier and a venting system.

A compilation of mitigation technologies is presented in table L-2.

Table L-2: Mitigation Technologies Mechanisms and Applications

Technology Type	Mitigation Technology	Mechanism	Applications/Locations
Barrier	Intumescent paint	Increases the reaction time to thermal stimuli	External casing surface
	Bore mitigant foam	Reduces impact loads from propellant debris	Rocket motor conduit
Venting	Fusible devices (plastics, metals)	Melts at temperatures well below the ignition temperature providing a vent path	Within end closures/caps
	Forward/aft venting plates	Allows pressure release through a large vent	
	Mechanical release	Releases a confining end closure at a pre-determined pressure or temperature	
	Stress riser groove	Allows the case to break open when pressure builds up	External casing surface
	Preferential insulation	Allows the case to fail along a non-insulated or less insulated area	
	Case cutters	Cut through the munition casing at a pre-determined pressure or temperature	
	Bonded structures	Lose mechanical strength at a temperature well below the EM ignition temperature during thermal exposure Under impact loads, perforation of the case creates a large entry and exit hole for subsequent venting. Reduces number of possible hazardous fragments	Casing
	Combustible cartridge case	Allows the case to fail through a thermal decomposition of the casing	Internal
	Pre-emptive ignition devices	Ignites the EM prior to its auto-ignition temperature	
Vented booster	Prevents pressure build up following the booster ignition	Junction booster/casing	
Dual-Purpose	Internal liner	Attenuates shock and bullet impacts and provides a vent path when thermally decomposed	Between energetic material and casing

2.2 Energetic Material Charge Design

Three design parameters could be considered:

- The charge dimensions. Designing a charge that is below the critical diameter when confined is certainly the most efficient way of avoiding a detonative event. Nevertheless, this is possible only for munitions components not required to detonate when functioning, i.e. the propulsion section.
- The presence of external gaps such as nose gap, base gap or surface voids. These voids are either designed to allow thermal expansion of the EM at the working temperatures (thermal shrinkage or expansion) or are inherent to the production process. To prevent compressive heating of air trapped, friction or shear, removing air, improving production quality control, removing irregularities from case surface, and using fillers (foam and felt mitigants) are possible solutions.
- The use of dual EM charges, one being less sensitive than the other one.

3. The Packaging Design

The principal roles of munitions packaging are to provide protection to the munitions against credible stimuli and to reduce the projection of explosive effects should the munition initiate. Any IM packaging solution must take in account the following constraints that have a major impact on the choice of available materials and technologies:

- Logistical and tactical storage and operational considerations
- For large numbers of relatively inexpensive munitions e.g. artillery shells, the cost of implementing the solution needs to be minimal
- Environmental impact

Akin to the techniques used for munition design, three principles can be applied to the design and configuration of the packaging.

3.1. Reduction of the Stimulus Energy

The only method applicable to reduce the stimulus energy transmitted to munitions is the use of packaging barriers. The type and configuration of any barriers will depend on the particular stimulus to be mitigated and any logistic constraints (such as weight, size etc.). Three types of barriers can be considered:

a. Mechanical Impact Barriers

Barriers suitable for defeating a mechanical threat do so by either stopping or decreasing the kinetic energy of the impactor. The important parameters in this process are the penetrator's length, diameter, velocity, density and strength and the barrier's density, strength, geometry and energy release.

The difficulty in designing the best barrier resides in the large threat magnitude. Each barrier is therefore application and threat-design specific. The tendency nevertheless is to design multicomponent armors that combine layers of dissimilar materials, e.g. usually a hard material to deform/strip the projectile and a somewhat flexible material (spall liner, fabric,...) to slow down the projectile and/or the debris.

These barriers need to be located in or around the packaging so that the sensitive parts of the munition (i.e. the energetic materials) are protected from impact from all possible angles. Beyond the limit of cost, the weight and the occupied volume of the usually retrofitted installed materials are critical.

Five main classes of materials and five main classes of material combinations achieved through multilayered materials or "sandwich structures" are identified in tables L-3 and L-4. Concerning cost issues, in general, materials get more expensive as one proceeds through the classes, just

as the cost of protection increases with the level of safety. Other concepts such as Non-Energetic Reactive Armour (NERA), Explosive Reactive Armour (ERA), Electromagnetic Armour, Smart Armours and Active Armours are not described in this section because generally used at a platform level.

Table L-3: Examples of Energy Absorber Materials

Materials	Example	Performance/Principles of operation
Geo materials	Granular materials (Pumice, soil...)	<ul style="list-style-type: none"> • See “shock impact barriers” section below
Polymers	Simple fabric (nylon) Polymer foams	
Metals	Steel such as <ul style="list-style-type: none"> • Rolled Homogeneous Armour (RHA) • Cast Homogenous Armour (CHA) • High Hardness Armour (HHA) Titanium such as <ul style="list-style-type: none"> • Ti-6Al-4V (TA6V) Aluminium Alloys such as <ul style="list-style-type: none"> • Aluminium-magnesium • Aluminium-magnesium-zinc • Aluminium-copper-manganese 	<ul style="list-style-type: none"> • Metals absorb the projectile kinetic energy through plastic deformation. <ul style="list-style-type: none"> ○ Metals with high density are more efficient against high velocity projectiles ○ Metals with high strength more efficient for low velocity projectiles. • Steel offers the best compromise between cost and resistance to penetration of all of the metals but at the expense of added weight to the application. • Titanium provides higher mass efficiency than steel and aluminium alloys but at a higher cost. • Aluminium alloys are comparable to steel in cost and penetration resistance, but require a much greater thickness. • Titanium and aluminium weight savings compared to steel is between 25% and 40% with aluminium having better machining and welding capabilities than Titanium.
Polymer matrix composites	Fiberglass Aramid Fiber Polyethylene fiber composites	<ul style="list-style-type: none"> • Can provide equivalent ballistic protection to metals but at reduced areal densities.
Ceramics	Alumina (Al ₂ O ₃) Boron Carbide (B ₄ C) Silicon Carbide (SiC) Titanium Diboride (TiB ₂)	<ul style="list-style-type: none"> • Ceramics absorb the projectile energy through fracture of the ceramic. • Ceramics have excellent hardness and strength properties that cause most penetrators to break upon impact, but are susceptible to brittle failure. • Pressureless sintered alumina is the most widely used due to its low cost, while reaction-bonded or hot pressed B₄C offers the best combination of performance and low weight.

Table L-4: Sandwich Structures

Concept	Principles	Performance/Principles of operation
Metallic hybrid laminates	Consists of a hard face that defeats the projectile by fracturing and a soft back that catches the debris.	<ul style="list-style-type: none"> Developed to improve performance over HHA. Difficult to form and weld.
Metal-Composite hybrids	Consists of a metal layer backed by a polymer matrix composite.	<ul style="list-style-type: none"> Developed to minimize debris.
Ceramic-Metal hybrids	Consists of a hard ceramic layer that defeat the projectile by breaking, shattering, eroding, dwelling or conditioning the projectile before it hits a hard metallic backing.	<ul style="list-style-type: none"> Metal-encapsulated ceramic have been developed to defeat medium and large caliber threats at a velocity of 1.3 to 1.6 km/s.
Ceramic-Composite hybrids	Consists of a ceramic backed by a polymer matrix composite.	<ul style="list-style-type: none"> More effective than metal backed designs on a weight basis. The large elastic and plastic deformations that result in the composite require additional engineering as well as design requirements for multi-hit capabilities.
Ceramic-Metal-Composite hybrids	Consists of Metal-Ceramic hybrids backed by a soft polymer matrix composite.	<ul style="list-style-type: none"> Developed to minimize weight and debris, and maximize performance. By combining metal or fiber composites as a backing material, the resultant ceramic composite armors offer excellent mass and space efficiencies, particularly for light and medium class armors. Assures a protection level 2-3 times better than RHA with a weight 2-3 times less.

Making benefit of the tumbling of moderate Length to Diameter ratio (L/D) projectile, mechanical impact barrier designers have also designed spaced targets that deflect the projectiles before defeating them. They consist of (n) homogeneous metal plates separated by (n-1) air gap or a sandwich target separated from a thin steel plate by an air gap. Against small arms projectiles, the performance of these barriers can be twice as effective as RHA on a weight basis.

b. Thermal Barriers

The key properties of effective thermal barriers are thermal conductivity and heat capacity. Possible technological solutions are given in table L-5.

Table L-5: Thermal Barrier Types

Solution	Principles of Operation
Fire-retardants	Increased temperature causes retardant materials to inhibit the combustion process.
Ablatives	Increased temperature causes a chemical transformation of the exposed surface forming a heat resistant layer. This layer requires further energy for removal.
Surface barriers	A gas-proof thermally insulating layer reduces heat transfer.
Intumescent paint	Exposure to heat transforms the paint into a rigid foam (by gas evolution followed by carbonisation) with low thermal conductivity. Preferential shielding can also be achieved using such a solution.

c. Shock Impact Barriers

Effective materials for shock attenuation need to be able to reduce acoustic and shock waves, peak overpressure, reflected overpressure, reflected peak overpressure, impulse and after-burn effects. This can be accomplished through:

- i. Shock decoupling. A shock propagates with a given speed, pressure and particle velocity relative to the shock impedance of the material through which it is propagating. Shock modification occurs when the shock wave encounters a discontinuity. At the interface with a material of different shock impedance, the shock is usually decoupled in a reflected and a transmitted shock. The reflected and the transmitted shock peak pressures can be reduced using a material with appropriate impedance.
- ii. Shock energy absorption/dissipation. Shock energy can be reduced by using the available energy to create irreversible material changes such as crushing of porous media or phase changes. Highly crushable, low compressive strength and high degree compressible materials are good candidates.

To prevent the barrier material to become a threat to the munition due to its projection or to become a more stringent threat to the surrounding munitions due to a shock reflection following a non-adapted impedance (high impedance mismatching results in increased reflection), it is possible to use materials that will break into small pieces or to use porous materials such that the shock can pass through.

Examples of possible technical solutions are given in table L-6.

Table L-6: Shock Impact Barrier Types

Solution	Examples
Shock decoupling	Water, water spray, water deluge
	Two phases materials (Confined stabilized aluminium foam, Aqueous foam)
	Multilayered materials with adapted impedance (Steel/PMMA, Aluminium/Plastic/Air/Plastic...)
Energy absorption	Materials with high extra-granular porosity/voids such as geo-materials in a confining skin (sand-cement, pumice, cement-bonded wood fiber)
	Materials with high intragranular porosity/voids such as <ul style="list-style-type: none"> • Pumice • Stone sponge • Honey comb filled or not with granular materials • Low density shock absorbing concrete • High porosity shock absorbing chemically bonded ceramic

3.2 Reduction of the Packaging Impact on Munition Response

If the munition reacts to a stimulus non-denotatively, confinement within the packaging could increase the severity of the response. If this is considered likely, the packaging will need to include some form of venting device or system to dissipate internal pressure build-up. This is akin to the technique used for munitions venting. In addition to venting systems, the packaging needs to be designed so that munition-venting devices can operate effectively.

3.3 Reduction of Explosive Effects

If the packaged munition reacts to a stimulus and produces explosive effects that are considered unacceptable, it will be necessary to mitigate these effects. This is often achieved through packaging and is often referred as shock hardening. Mitigation of these effects can be achieved by:

- The use of suitable barriers within the packaging to absorb energy (shock/thermal). It is recommended to refer to the section related to the reduction of the stimulus energy input into the munition for more information on the possible technologies to be used.
- An appropriate spatial distribution of the munitions to prevent the reacting munition to become or to create a more stringent threat to other munitions such as in the diagonal effect. Diverters within munition packaging can also be used to prevent this geometry dependent effect.

4. **Design techniques for Fuzes**

4.1. Introduction

Listed are the requirements for an IM Fuze.

- That it meets the STANAG 4187 requirements.
- That it meets the STANAG 4439 requirements.
- That by its inclusion in a system it does not degrade the system IM signature.
- That it reliably functions in all the required operating conditions.
- That it effectively initiates the munition in its design mode.

STANAG 4187 is the NATO agreement covering Fuzing Systems – Safety Design Requirements and in the primary document in all fuze design requirements.

Where fuze methodology has been incorporated in Ignition Safety Devices STANAG 4368 then these techniques may also be applicable.

STANAG 4187 states “the required safety design features shall prevent initiation of the booster until the fuze is armed”. Therefore the required safety design features should prevent initiation of the booster until the fuze is armed. However if the IM testing aggressions, which are more severe than normal environmental and accident testing, (as described in STANAG 4439) are applied then these aggressions should not cause the fuze booster to respond in such a way as to initiate the explosive train.

The fuze must have the means of reliably initiating the main charge under all operational conditions. In general the main charge will be a secondary explosive and in more and more cases will be an Energetic Material (EM) that is suitable for IM applications therefore it will exhibit low vulnerability.

In the case of a fuze such as a traditional Artillery fuze, with an out of line initiator and a barrier, it is acceptable that the sensitive part of the fuze, the detonator, can be a primary explosive as long as the testing detailed in AOP 20 Test D1, Primary Explosive Component Safety (also known as the Explosive Train Interrupt Test (ETIT)) passes. The result of this test gives confidence that the interrupter (barrier) will prevent any form of propagation from a detonator to the fuze booster. The difficulty in this is that if the booster filling in the fuze has been changed to a less sensitive filling, then reliable initiation may require a more powerful detonator in the fuze or a detonator that is more focused in its output.

To achieve a reliable take over to the main energetic filling the output of the fuze will need to be tuned to the system.

The interfaces between the explosive train are shown in Table L-7.

Table L-7: Explosive Train Interface

	Function	Power	Material
Initiator	Sensitive	Low	Primary Explosive
Lead	Sensitive enough	Medium	As insensitive as possible
Fuze booster	Sensitive enough	Medium	Secondary explosive
Munition booster	Insensitive	Med/High	Secondary explosive
Main fill	Insensitive	High	Secondary explosive

4.2. Discussion

Fuzing systems fall into 2 categories and they are “in line systems” and “out of line systems”.

In Line systems should not contain any primary explosives and must be initiated by one of a number of techniques that have been developed in relatively recent history. Examples are EFI, EBW, Slapper and Laser.

a. Considerations for IM Fuzes

Explosive Train Initiation Technology

Testing carried out on fuzing systems makes the assumption that the fuze has not been damaged physically other than induced ageing. Fuzes in mortars and artillery shells are normally situated at the nose of the projectile and in recent years have been constructed of lighter materials such as aluminium and plastic. It is not unrealistic to consider the possibility that some fuzes will be susceptible to damage. This can be through routine handling accidents or even external aggressions such as bullet, fragment etc. Therefore it is also reasonable to consider the integrity of the design such that a path for the primary explosive output may be created that could reach the fuze booster. It would therefore be desirable to reduce this threat by removing more sensitive material and introducing other means of initiating the booster such as in line fuze initiation devices. These currently consist of Slapper, EBW, EFI, and Laser and are used in In-Line systems. Whereas this may not currently be possible in small or low cost munitions because of space or cost considerations it may be possible in the future.

Making an in line system safe that uses electrical initiated ignition systems, will require that un-demanded initiation cannot be caused by incorrect logic or unwanted electromagnetic power sources. These aspects of the fuze and the safety and arming unit will not be addressed here, however it is a primary consideration for in-line systems. Testing and assessment of these designs is addressed by the STANAGs and AOPs listed at the end of this Annex.

With an out of line system the detonator, the first element in the explosive train, is separated from the next element by a physical barrier until the fuze is armed. Provided that the AOP 20 test D1 is successfully completed it is only necessary to consider the energetic material which is below the barrier. To be an acceptable solution the initiation system must function under all the required environments and through the full life of the munition, or at least only fail safely and within the required reliability targets. However to achieve the IM requirements the fuze explosive train must be as insensitive to shock as possible and thermal aggression must not result in munition response greater than burning. The key point is that the explosive used must be suitable to be either ignited or shocked and transfer to detonation whilst at the same time not being susceptible to accidental initiation from threat environment such as fuel fire, slow heating or handling shocks.

b. Fuze Booster

The explosive used in the fuze booster must be sufficiently sensitive and have adequate explosiveness to propagate the explosive train by detonation whilst at the same time not being susceptible to accidental ignition or detonation.

4.3. Fuze Design

In the same way as for the main weapon the most effective method for achieving successful Insensitive Munition (IM) fuze design is to use a systems approach. The key elements in the IM fuze systems approach are:

- The energetic materials (EMs);
- Mitigation technology;
- System aspects relating to the fuze.

The energetic material is fundamental in the fuze design and will be reviewed in more detail. Mitigation Technology is more appropriate to the munition as a whole and only specific fuze aspects will be reviewed. Systems aspects relating to the fuze will also be reviewed.

a. The Energetic Material Selection

The main points about energetic material selection are reviewed earlier in Annex L however there are extra considerations with the fuze as part of the system. There will be different considerations when the fuze is transported separately and these are not reviewed here other than to propose that it would be illogical to employ excessive confinement in the packaging of fuses to the extent where a problem such as an explosion and debris is created after a credible accident event.

The factors in deciding which EM to be used are listed:

- Cost (of less importance than the main explosive filling due to the reduced quantity in use)
- Performance (critical in that reliable operation in the design mode is essential)
- Producibility (infrastructure and availability of materials and ingredients)
- Technology maturity (development status, specifications, in production, in-service, combat proven...)
- Health and Safety (Environmental considerations, toxicity...)
- Compatibility with other EM and materials used in the munition
- Sensitiveness to shock, heat and impact, resist set back initiation
- Ageing
- Compatibility
- Disposal

A fuze booster (ie embedded in the fuze) needs to be designed to initiate the main charge or main charge booster, when subjected to a specific energetic input yet resists all other stimuli. Material qualification in accordance with the requirements of STANAG 4170 and AOP-7 will provide the necessary data to inform the designer of sensitivity to shock, friction, electrostatic, ignition temperature etc. UN EIDS 1.6 would also be a desirable goal. It must also be compatible with other system components in accordance with STANAG 4147.

When selecting a suitable EM for an IM application, it is highly desirable that it possesses inherent low vulnerability (i.e. reduced response) to the IM stimuli (mechanical and thermal). The factors that contribute to the EM response are discussed below.

b. Response of the EM to shock stimuli.

This aspect is reviewed at Annex L 1.1 for the main IM filling. It is correct to say that the fuze booster will need to be susceptible to shock initiation and to amplify and pass on that shock wave as designed in order to initiate the main charge. The factors that need to be considered are orientation, confinement, temperature and density. All of these will have an effect on the critical diameter and run to detonation distance. The fuze design must also take into account the booster configuration such that no dead zones are caused by pre-shock and corner turning problems with the main EM filling. The science will not be reviewed here. It is important that these properties are considered and the fuze is correctly designed, manufactured and tested, and that they remain consistent. Therefore the following properties are essential.

EMs should, wherever possible, have the following characteristics:

- Good mechanical properties:
 - High resistance to damage;
 - Non friable;
 - Toughness (high elongation with plastic failures, particularly at low temperature limits and high loading rate;
 - Low glass transition temperature);
 - Low elastic modulus binders;
- High specific heats and heats of fusion polymers to encourage hot spot quench
- Low sensitivity components;
- Particle distributions that are optimum for binder wetting and particle to particle bond strength;
- Minimum porosity.

c. Response of the EM to thermal stimuli

The cook-off environment is a much greater risk in terms of probability than inadvertent accidental or deliberate initiation by shock. There are many reasons for this but just considering the difficulty of directing a projectile, fragment, shaped charge or long rod with sufficient energy to contact the fuze booster without providing de-confinement as well as having breached the exterior casing is less likely compared to the probability of a simple event of a fire. Therefore slow and fast heating need to be addressed. Cook-off involves chemistry and physics and covers a diverse range of subjects such as combustion, material properties and thermal explosion theory. This is reviewed at Annex L section 1.2.

The key factor in determining the final violence of response is the order of magnitude of the pressure increase, i.e. the pressurization rate and again is reviewed in Annex L section 1.2.

4.4. The Munition Design – Fuze Aspects

Hardware Material Selection and Design

As discussed in Annex L 2.1 venting/de-confining technologies are aimed at releasing or preventing the catastrophic build-up of pressure due to the reaction of the energetic material. In the case of the fuze the technique of having weakened threads or a fuze adaptor which softens or melts so that the fuze can be expelled, have been used.

Concerning the mitigation techniques, the venting systems can be divided into two basic types, active and passive.

- Active systems rely on the initiation of an energetic device to cut open the case or create sufficient weakness to allow a relatively benign separation at a certain pressure.
- Passive systems rely on chemical or physical changes within specific materials to allow the creation of vent holes or the benign expulsion of end plates/closures.

A compilation of mitigation technologies available are presented in Annex L Table 2. [Mitigation Technologies relevant to munitions design and possible localizations]. The fuze housing is an obvious choice for venting in shell and mortars but may not provide sufficient venting for larger munitions. However in the case of a fuze explosive train that incorporates a primary explosive the separation (removal) of this element of the explosive train from the booster or main charge may well be desirable.

4.5. Energetic Material Fuze Design

Three design parameters could be considered:

- The charge dimensions. Designing a charge that is below the critical diameter when confined is certainly the most efficient way of avoiding a detonative event. Nevertheless, this is possible only for munitions components not required to detonate when functioning, i.e. the propulsion section. A possible development might be to separate two halves of the booster and only bring them together after safe arming.
- The presence of external gaps (nose gap, base gap or surface voids for example). The quality of the filling in terms of homogeneity needs to be high; therefore the following features are undesirable and should be avoided by design and good quality control, air gaps, voids, porosity and cracks. The general design which might allow movement is to be avoided. It is expected that the volume involved should not lead to large expansion or contraction. To prevent compressive heating of air trapped, friction or shear, removing air and using fillers (foam or felt) are possible solutions.
- The use of dual EM charges, one being less sensitive than the other one. Thus using the smallest amount of the sensitive EM material as possible and minimising the potential target area of the threat. Although there may be increased manufacturing issues the system can be tuned to function reliably whilst minimising the risk and cost. The principle is already employed in explosive trains or indeed in different pressing densities in detonators thus minimizing the most sensitive areas.

4.6. System aspects relating to the Fuze

The Packaging

Discussed earlier in Annex L for the general munition design, however increasing the level of protection in the most vulnerable areas is worth considering and there are various options here depending on the threat hazard assessment (THA). A mechanical barrier around the fuze and booster if they have an unacceptable response to a credible threat. A thermal barrier to ensure that the desired ignition of the main EM or the activation of a mitigation device before the booster detonates.

If the fuze reacts to a stimulus non-denotatively, confinement within the packaging could increase the severity of the response. The packaging needs to be designed so that munition-venting devices can operate effectively. i.e. space for the fuze to move away from the vented munition.

4.7. Technology Available That Can Help to Improve the IM Signature

Table L-8 lists the IM design concepts and technologies applicable to fuzing systems.

Table L-8: IM Technology for Fuzing Systems

IM Design Concept	IM Technologies
Cook off resistant booster and lead	See table L-10
Thermal insulating materials	Intumescent coatings
	Polymeric liners
	Insulated sleeves
Venting systems	Fuze expulsion
	Fusible plugs
	Stress risers
	Frangible joints
	Shaped memory alloys
	Booster venting holes
Minimizing confinement	Selecting suitable materials and fuze configuration

IM Design Concept	IM Technologies
Minimize EM quantity by shape	Monroe Effect booster
	Inverse Monroe Effect booster
	Ring booster
	Conical booster
	Ring and can booster imbedded plate
	Mach wave generators
Minimize EM quantity (booster size)	Increased booster explosive performance (replacement of RDX by HMX)
Special booster fuze booster housing	Flyer plate
	Multiple Point Initiation (MPI)
In-line Initiator	Explosive Foil Initiator (EFI)
Increase initiation reliability	Embedded and protected booster
	Increase booster explosive performance (use of metal accelerating HE)
Thermally mitigating and shock attenuating packaging	Shock mitigating materials and barriers
	Intumescent paint on the container (delay cook-off reaction)

Assessment of the available techniques is given in table L-9 and includes an indication of the relative cost, reliability and disadvantages.

Table L-9: Relative Assessment of Available Technologies

Technology	Benefits	Cost	Reliability	Disadvantages
New booster explosives	Reduced shock sensitivity Cook-off resistant	Low to medium (TATB, HNS)	High	Output needs to be tailored to ensure main charge functions. Full qualification testing required
Intumescent coatings	Delays booster initiation and provides uniform thermal input	Low	High	Increases mass and volume. If incorporated in the munition then compatibility issues need addressing
Polymeric liners	Delays booster initiation and provides uniform thermal input	Low	High	May reduce booster confinement. Mechanical properties may change with ageing
Insulated sleeves	Delays booster initiation and provides uniform thermal input	Low/ Medium	High	Increases mass and volume
Fuze expulsion	No risk of transmission of an initiation to the main charge	Low/ Medium	Medium/ High	In a packaged munition space needs to be made available for the fuze to separate therefore increased logistic container volume
Fusible plugs	Prevents pressure built-up	Low/ Medium	High	Need protection from Aero-heating and may age.
Frangible joints	Prevents pressure built-up	Low	High	Weakness of the housing (high-g environment), ageing
Shaped memory alloys	Prevents pressure built-up	Low/ Medium	Medium/ High	Ageing
Booster venting holes	Prevents pressure built-up	Low	High	Reduces booster confinement
Specific booster shape	Improves booster performance, can reduce fuze mass and volume	Low/ Medium	Medium/ High	Manufacturing process (assembly accuracy)
Mach wave generators	Improves booster performance, minimizes fuze mass and volume	Low/ Medium	Medium/ High	Manufacturing process (assembly accuracy)
Increased booster explosive performance	Improves initiation reliability, reduces "duds", reduces booster direct hit probability, re-allocates volume for other fuze functionalities	Low to medium (TATB, HNS)	High	Output needs to be tailored to main charge functioning, extensive testing for safety and reliability
Flyer plate	Improves initiation reliability, reduces "duds"	Medium/ High	High	Manufacturing process (assembly accuracy)
Multiple Point Initiation (MPI)	Improves initiation reliability, reduces "duds", reduces risk of inadvertent initiation	Medium/ High	High	Manufacturing process (assembly accuracy)
Explosive Foil Initiator	Reduces Safe and Arm Unit Cost	Medium	High	Manufacturing process (assembly accuracy)

4.8. Reduced Vulnerability Energetic Material Used in Fuze Boosters

Most conventional booster explosives such as Tetryl, CH-6, or Composition A-5 react violently when subjected to a fuel fire. Cook-off resistant booster explosives have been developed and 3 common options are HMX, HNS and TATB based compounds or mixtures.

Cook-off resistant boosters that are or have been in use:

- B-2188
- B-2238
- P-63
- Rowanex-3601
- PBXN-5
- PBXN-7

These boosters have either performance limitations (e.g., PBXN-7), especially at low temperature, or cook-off behaviour limitations (e.g., PBXN-5). TATB is still considered because of its excellent cook-off behaviour. RDX can be replaced by HMX as the nitramine to improve the performance:

- PBXW-14
- V-350
- ORA-86
- PBXN-9
- PBXN-110

TATB and HNS are relatively expensive, therefore fuze booster's manufactured with these energetic materials are more costly when compared to those made with composition A5. NTO has been considered as a potential replacement for TATB.

Limited IM testing has been reported on mechanical threats (BI, FI or SCJ) on fuzing systems particularly when embedded in weapons. However it has been assessed that the new booster explosives should pass bullet impact but will have difficulty passing fragment impact testing. However when the fuze is integrated into a munition (the munition design provides additional mechanical barriers to the initial IM stimuli). Shaped Charge is more problematic, however in a risk assessment, a shaped charge is likely to initiate the main charge anyway and the effect of the aggression on the whole system should be considered as well as the reduced probability of a hit on the relatively small booster.

4.9. Improvements in IM versus System reliability

The interoperability between fuzes and munitions is generally described in design standardisation documents (e.g., STANAG 2916 - Nose Fuze Contours and Matching Projectile Cavities For Artillery and Mortar Cavities) as interface drawings: no information or requirements on take-over characteristics in the explosive train are provided. As an example, of the potential difference between compositions the replacement of composition A5 (calculated detonation pressure around 32.8 GPa) by PBXN-7 (calculated detonation pressure around 25.2 GPa) in a fuze booster might increase the number of misfires if no additional design techniques were to be integrated into the design. A proper assessment of the different solutions ("IM" fuze with non-IM shell, non-IM fuze with IM shell, etc) is required. One possible solution is to increase the fuze booster size or to incorporate another booster into the munition design. The time taken for procurement of new systems may mean that if a conventionally non IM fuze were to go out of service before an unfuzed shell or bomb, then the new fuze system would ideally still have enough energy output to initiate the older munition. The opposite may also be required operationally i.e. a conventional fuze should also work with a reduced sensitivity energetic material filled munition although this situation should be avoided if possible.

Table L-10 - Candidate or In Service Booster Formulations

Explosive	Formulation	Type	Applications
B-2188 A	PETN/HMX/PU: 44/40/16	PBX	Missiles
B-2238	RDX/HTPB: 85/15	Cast PBX	Missile warheads
B-2248	HMX/NTO/HTPB: 42/46/12	Cast PBX, EIDS	Qualified
DIPAM	(Hexanitro-dipheny-diamine)		Qualified lead and booster explosive
DXP-1380	HMX/binder (Hytemp/DOA): 92/8	Pressed PBX	Qualified booster explosive
DXP-1340	(HMX/binder (Hytemp/DOA): 96/4)	Pressed PBX	-
DXP-2380	(RDX/binder (Hytemp/DOA): 92/8)	Pressed PBX	Qualified booster explosive
DXP-2340	RDX/binder (Hytemp/DOA): 96/4	Pressed PBX	-
FPX-P1	PETN/HTPB/DOS/IPDI	PBX	-
FPX-P2	PETN/HTPB/DOS/IPDI	PBX	-
HK5	HNS/KeLF	Pressed PBX	76-mm and 155-mm
HNS Type 1		Pressed	Qualified booster and lead explosive
ORA-86	HMX/PU: 86/14	Cast PBX	Qualified booster of bomb
P-15636	HMX/NTO/Binder	PBX	Booster and metal accelerating explosive
P-63	HNS/Binder: 94/6	Pressed PBX	Qualified booster explosive
PBX-9502	TATB/KeLF-800: 95/5	Pressed PBX	Qualified EIDS booster explosive
PBX-9407	RDX/EXON 461: 94/6	Pressed PBX	Qualified booster explosive
PBXN-5	HMX/Viton: 95/5	Pressed PBX	Qualified booster explosive used in several warheads
PBXN-6	RDX/Viton A: 95/5	Pressed PBX	Qualified booster explosive
PBXN-7	RDX/TATB/Viton A: 35/60/5	Pressed PBX	Qualified booster explosive used in several warheads
PBXN-9	HMX/Hytemp/DOA: 92/6/2	Pressed PBX	Qualified booster explosive for missile warhead
PBXN-10	RDX/Hytemp/DOA: 94/1.5/4.5	Pressed PBX	Qualified booster
PBXN-110	HMX/HTPB/IDP/Other: 88/5/5/2	Cast PBX	Booster for an underwater IM demonstrator
PBXN-301	PETN/Silicone	Extruded PBX	
PBXW-14	HMX/TATB/Binder	Pressed PBX	Booster explosive in development
Rh-83	Unknown	Pressed PBX	
Rowanex 3601	RDX/TATB/TPE: 35/60/5	Pressed PBX	
V-350	HMX/TATB/Binder: 45/52/3	Pressed PBX	Qualified booster
XTF-111G	HNS/Binder	Pressed PBX	4.5-inch naval shell

Note: The Table is not considered to be exhaustive and qualification data would need to be provided in accordance with STANAG 4170 before use in a STANAG 4187 qualified Fuzing system.

4.10. Applicable Associated or Related NATO Documentation

STANAG 4187	Fuzing Systems: Safety Design requirements
STANAG 4157	Fuzing Systems: Test Requirements for the Assessment of Safety and Suitability for Service
STANAG 4170	Principles and methodology for the Qualification of Explosive Materials for Military Use
STANAG 4147	Chemical Compatibility of Ammunition Components with Explosives and Propellants
STANAG 4327	Lightning, Munition Test Procedures.
STANAG 4326	NATO Fuze Characteristic Data (AOP 8)
STANAG 4363	Fuzing Systems - Development Testing for the Assessment of Lead and Booster Explosive Components.
STANAG 4368	Electric and LASER Ignition Systems for Rockets and Guided missile Motors Safety Design
STANAG 4369	Design Requirements for Inductive Setting of Large Calibre Projectile Fuzes.
STANAG 4370	Environmental Testing
STANAG 4397	NATO Catalogue of Explosives
STANAG 4416	Nuclear Electromagnetic Pulse, Test Procedures.
STANAG 4423	Cannon Ammunition Safety and Suitability for Service Assessment
STANAG 4518	Safe Disposal of Munitions, Design Principles and Requirements, and Safety Assessment.
STANAG 4547	Design Requirements for Inductive Setting of Medium Calibre Projectile Fuzes.
STANAG 4560	Electro-Explosive Devices, Assessment and Test Methods for Characterisation
STANAG 4593	Fuzing Systems - Design Requirements for Inductive Setting of
AOP-7	Manual of Tests for the Qualification of Explosive Materials for Military Use.
AOP-8	NATO Fuze Characteristics Data.
AOP-20	Manual of Tests for the Safety Qualification of Fuzing Systems
AOP-21	Fuzing Systems: Manual of Development Characterisation and Safety Test Methods and Procedures for Lead and Booster Explosive Components.
AOP-15	Guidance on the Assessment of the Safety and Suitability for Service of Munitions for NATO Armed Forces.
AOP-16	Fuzing Systems - Design Guides.
AOP-22	Design Criteria and Test Methods for Inductive Setting of Electronic Projectile Fuzes
AOP-42	Integrated Design Analysis for Fuzing and Safety Critical Systems
AOP-43	Electro-Explosive Devices: Test Methods for Characterization: Guidelines for STANAG 4560
AECP-1	Mechanical Environmental Conditions to which Materiel Intended for Use by NATO Forces could be Exposed.
AECTP-500	Electrical Environmental Test.
AQAP-110	NATO Quality Assurance Requirements for Design, Development and Production.

4.11. Applicable Associated or Related National Documents

France

GAM DRAM 01 Measurements of the Characteristics of Explosive Components – Test Procedures G.T.P.S. No. 12 (May 1987)

Germany

TL 1375- 1100 Electro-explosive Devices - General Requirements.
VG 95 378 (Part 3) EMC of Electro-Explosive Devices (EED) Fundamentals for Determining Characteristic Values.

UK

Def Stan 07-85

Pillar Proceeding P101 (2) Principles for the Design and Assessment of Electrical Circuits
Incorporating Explosive Components.

Pillar Proceeding P112 (1) Electro-Explosive Devices Assessment and Characterization.

USA

MIL-STD 1316E Fuze Design, Safety Criteria for

MIL-STD-1512 Electro-explosive Subsystems, Electrically Initiated, Design Requirements
and Test Methods.

MIL-STD-1576 Electro-explosive Subsystem Safety Requirements and Test Methods for
space system

MIL-STD 331 Fuze and Fuze Components, Environmental and Performance Tests for

MIL-STD 333 Fuze, Projectile and Accessory Contours for Large Caliber Armaments

MIL-HDBK 145 Fuze Catalog - Active Fuzes

MIL-HDBK 146 Fuze Catalog - Limited Standard, Obsolescent Obsolete, Terminated and
Cancelled Fuzes

MIL-HDBK 777 Fuze Catalog - Procurement Standard and Development Fuze Explosive
Components

MIL-HDBK 504 Guidance on Safety Criteria for Initiation Systems

MIL-STD 1901 Munition Rocket and Missile Motor Ignition M System Design, Safety Criteria
for

MIL-STD 1911 Hand- Emplaced Ordnance Design, Safety Emplaced Ordnance Design,
Safety Criteria for

MIL-I-23659 Initiators, Electric, General Design Specification (MIL-DTL-23659).